A large aerial satellite image of a river delta, showing a complex network of channels and distributaries. The land is a mix of green and brown, with a large body of water at the bottom left.

# Pathway to Future Sustainable Land Imaging: The Compact Hyperspectral Prism Spectrometer

Tom Kampe  
Bill Good

**NASA Earth Science Technology  
Forum 2017**  
*California Institute of Technology*  
June 13-15, 2017

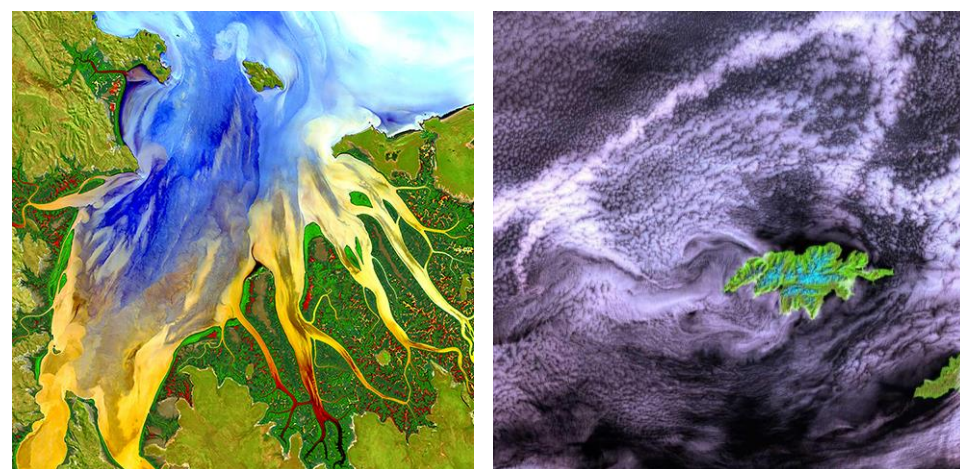

# Sustainable Land Imaging in the Future



## The SLI-T program aims to

- *Reduce the risk, cost, size, volume, mass, and development time for the next generation Sustainable Land Imaging (SLI) instruments while meeting or exceeding the current land imaging capabilities;*
- *Improve temporal, spatial, and spectral resolution of SLI measurements; and*
- *Enable new SLI measurements that can improve operational efficiency and reduce overall costs*
- *Maintain continuity with heritage Landsat instrument to continue 40+ year data series*

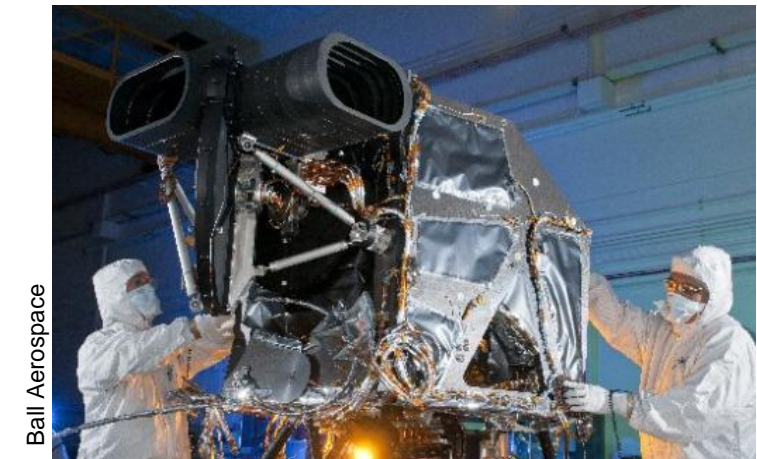
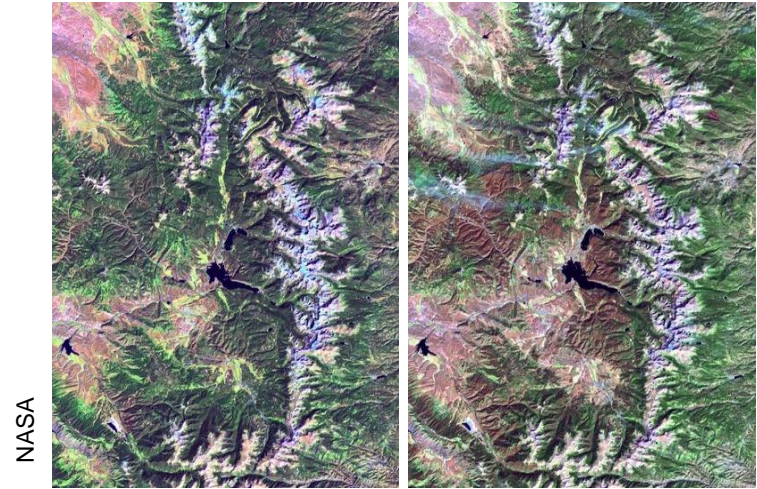



# SLI-T Compact Hyperspectral Prism Spectrometer (CHPS)



**CHPS is a pushbroom prism imaging spectrometer operating over the VSWIR region**

- Multiple channels binned to provide the heritage SLI bands
- Continuous high spectral resolution from 400 to 2500 nm provides spectroscopic information to support wide range of emerging land science products:

- *Plant functional types and distribution*
- *Intelligent agriculture (crop selection, water use practices, drought mitigation, etc.)*
- *Ecological disturbances (invasive species, wild fires, forest thinning and dieback, insect infestation, etc.)*
- *Near-shore Coastal Water Science (chlorophyll concentrations, algae blooms, water pollution)*

SLI-T Band Name	CWL(nm)	CWL Tolerance (nm)	Min Lower Band Edge (nm)	Max Upper Band Edge (nm)
Coastal Aerosol	443	2	433	453
Blue	482	5	450	515
Green	562	5	525	600
Red	655	5	630	680
NIR	865	5	845	885
SWIR 1	1610	10	1560	1660
SWIR 2	2200	10	2100	2300
PAN	590	10	500	680
Cirrus	1375	5	1360	1390
Thermal 1	10800	200	10300	11300
Thermal 2	12000	200	11500	12000

# Top-Level Parameters – Airborne Demo Instrument



Parameter	Value
Aircraft	Twin Otter De Havilland DHC-6
Flight altitude	4000 m AGL nominal; 5486 m (18,000 ft) max
Ground sampling distance	2.5 m
Aircraft velocity	50 m/sec
Hyperspectral spectral coverage	400 – 2500 nm; 1.6 to 10 nm/pixel sampling
Required SLI Spectral Bands	Data binned to generate SLI Bands 1-9
Instrument Environment	Pressure-controlled enclosure; thermally controlled
In-flight calibration	Spectral and radiometric calibration before and after every flight line
Typical flight day	4.0 hours; 3.25 hours of data collection
On-board electronics & data system	Controls data acquisition, telemetry and data archiving; real-time display of data; instrument control
Data volume, typical flight day	~ 1 Tb
Ground data system	Management and archiving of data acquired during flights; Quick-look data assessment

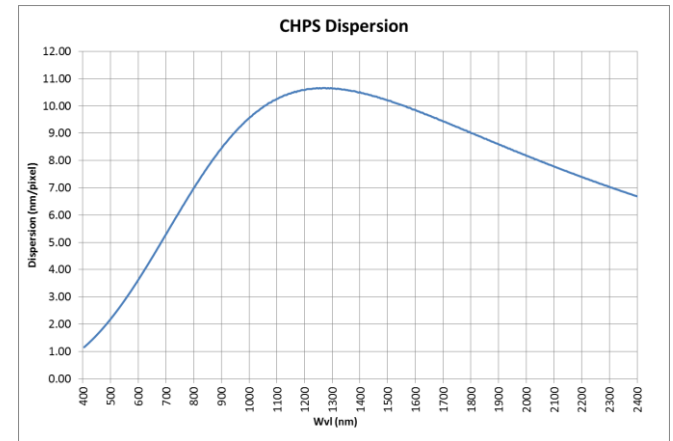

- Current effort is on development of airborne demonstration instrument

# SLI Radiometric Requirements Being Met

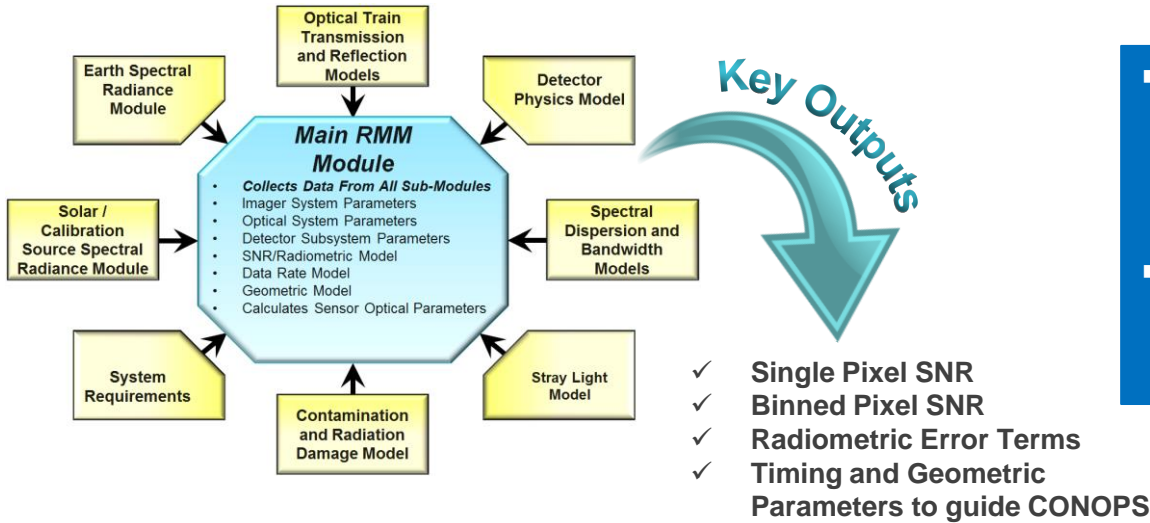

- Radiometric math model (RMM) developed to compute SNR performance for single and binned pixels
- Model is adaptable to the spaceborne version of SLI-T CHPS

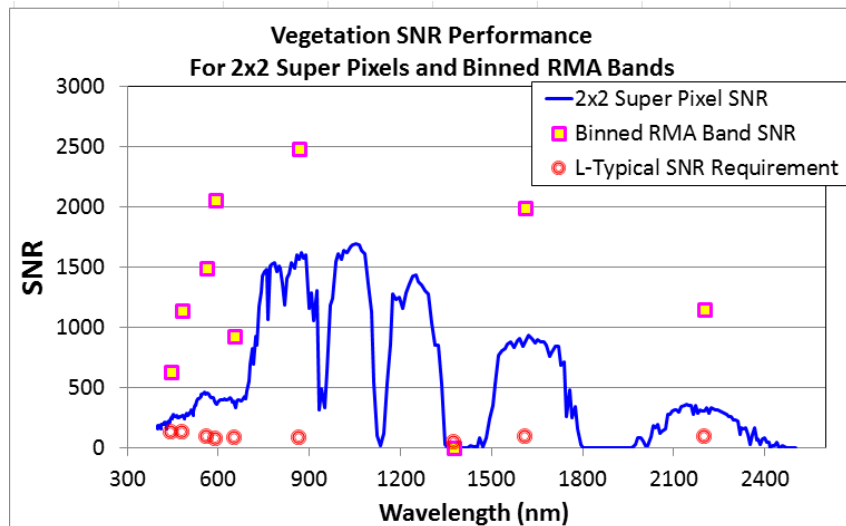

# RMA SNR Requirements Are Met for Both the 2x2 Super Pixel and Binned RMA Band Resolutions

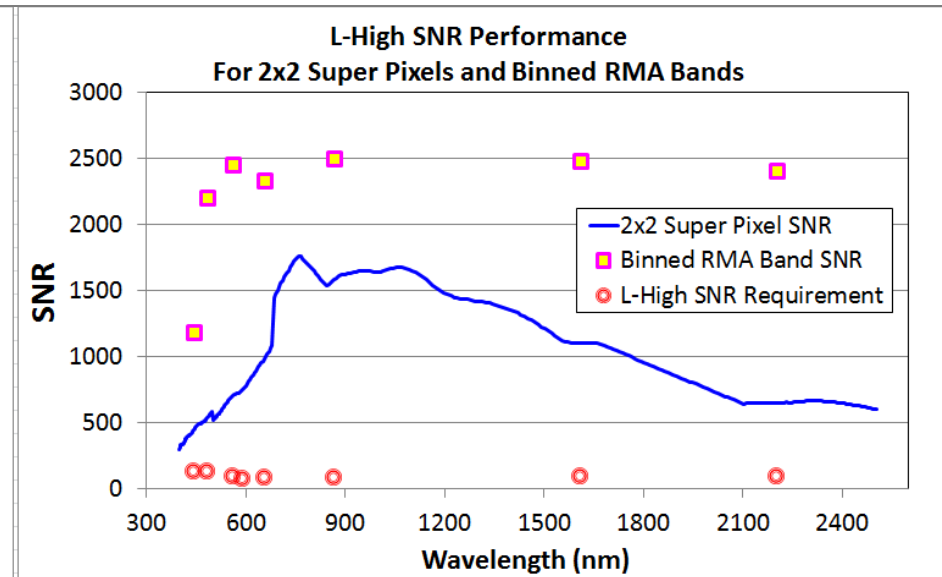
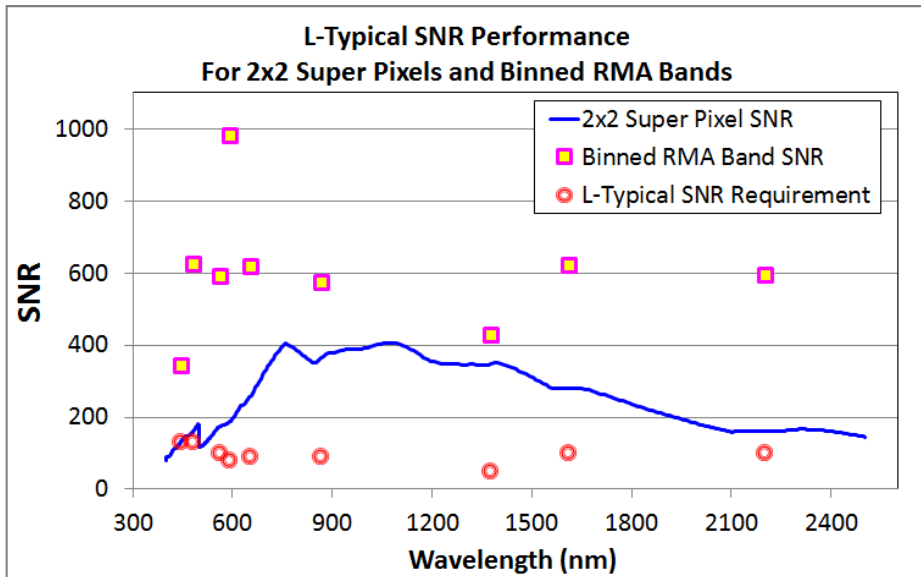

## Binned RMA Band SNR Requirements & Performance Summary

Wavelength Band Designation	Wavelength Range (nm)	Center WL (nm)	SNR Reqmt	SNR Reqmt	SNR Perf	SNR Perf	Margin	Margin
			L Typical	L High	L Typical	L High	L Typical	L High
1 -- Coastal Aerosol	433 - 453	443	130	290	344	1190	164%	310%
2 -- Blue	450 - 515	482	130	360	627	2205	382%	512%
3 -- Green	525 - 600	562	100	390	593	2455	493%	529%
4 -- RED	630 - 680	655	90	340	619	2333	588%	586%
5 -- NIR	845 - 885	865	90	460	575	2502	539%	444%
6 -- SWIR 1	1560 - 1660	1610	100	540	623	2481	523%	359%
7 -- SWIR 2	2100 - 2300	2200	100	510	594	2408	494%	372%
8 -- Panchromatic	500 - 680	590	80	230	983	3987	1129%	1633%
9 -- Cirrus	1360 - 1390	1375	50	N/A	428	N/A	755%	N/A

# Spatial / Spectral Requirements also Important



**Instrument SNR performance is only one aspect of the system design**

- Other demanding requirements include the spatial requirements
  - Half-edge slope
  - Edge Response
  - Aliasing

**Cross-track:**

- Viable Aliasing space limits design options
- Aliasing benefits from higher F/# (smaller EPD, larger FL)

**Along-track:**

- Edge Slope margin constrains design space
- Edge slope margin benefits from shorter FL

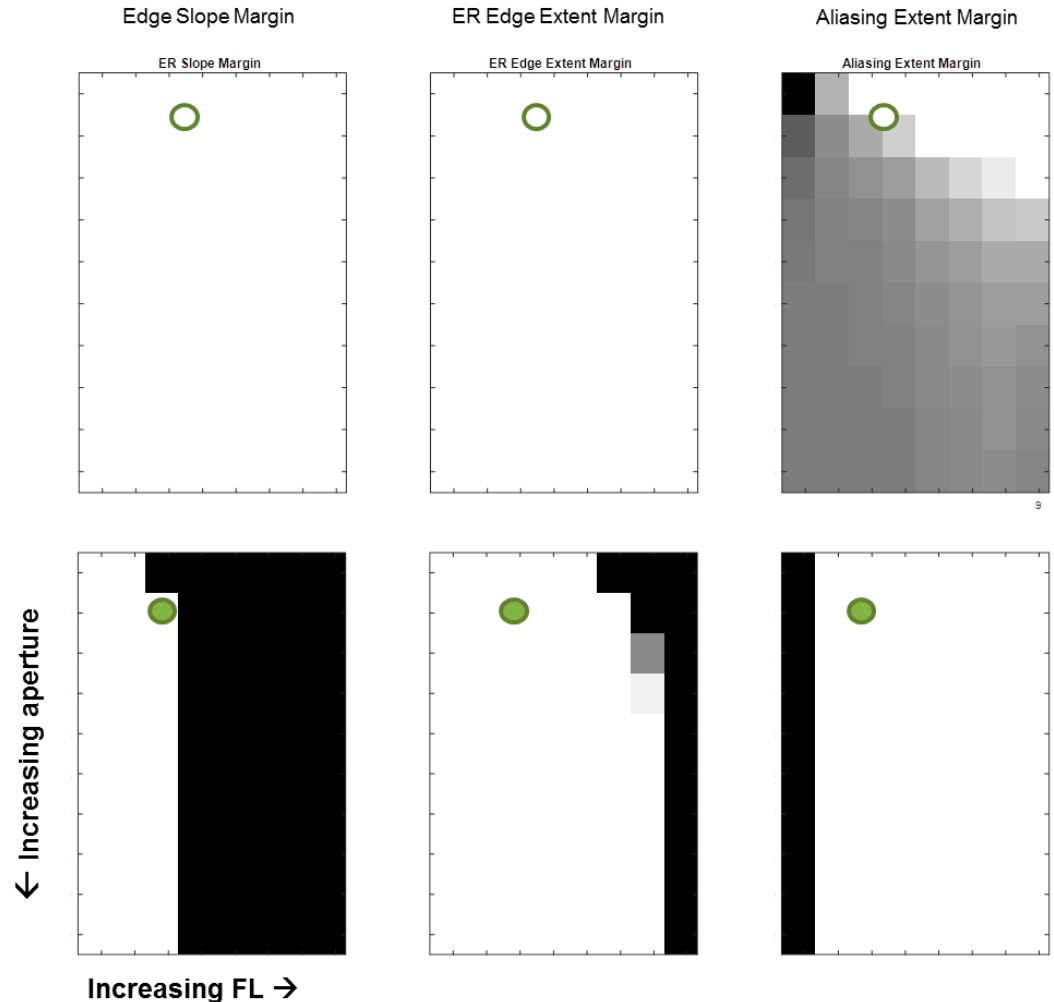

# Scaling SLI-T RMA Requirements for Airborne Demo



- SLI RMA spatial requirements derived for a spaceborne instrument in a 705 km equatorial polar orbit
- CHPS airborne demonstration instrument will fly at 4 km altitude
- Therefore, spatial requirements are scaled by GSD to be proportional to the spaceborne requirements while providing data at a spatial resolution useful for deriving land science data products

Band Number	Band	Airborne Requirements				SLI Spaceborne Reference Mission Requirements			
		Nominal GSD (m)	Minimum Edge Slope	Maximum Half Edge Extent		Nominal GSD (m)	Minimum Edge Slope	Maximum Half Edge Extent	
				(m)	Fraction of GSD			(m)	Fraction of GSD
1	Coastal Aerosol	2.50	0.324/m	1.92	0.77	30	0.027/m	23.0	0.77
2	Blue	2.50	0.324/m	1.92	0.77	30	0.027/m	23.0	0.77
3	Green	2.50	0.324/m	1.92	0.77	30	0.027/m	23.0	0.77
4	Red	2.50	0.324/m	1.96	0.78	30	0.027/m	23.5	0.78
5	NIR	2.50	0.324/m	2.00	0.80	30	0.027/m	24.0	0.80
6	SWIR 1	2.50	0.324/m	2.33	0.93	30	0.027/m	28.0	0.93
7	SWIR 2	2.50	0.324/m	2.42	0.97	30	0.027/m	29.0	0.97
8	Pan	1.25	0.324/m	1.17	0.93	15	0.027/m	14.0	0.93
9	Cirrus	2.50	0.324/m	2.25	0.90	30	0.027/m	27.0	0.90



# Out of Band Stray Light Performance



- Compared with integrated out of band requirement of 2% or less – predicted performance below requirement in all bands except Cirrus\*
- Out of band relative response level requirement less than 0.001 – predicted greater than 50% margin in all bands evaluated

## Integrated OOB Performance (<2% Req't):

Band Number	Band	CWL (nm)	OOB SL
1	Coastal Aerosol	443	1.50%
3	Green	562	1.05%
4	Red	655	1.37%
9	Cirrus	1375	2.20%
7	SWIR-2	2200	1.86%

**\*Note: Cirrus OOB performance can be reduced with lower contamination level assumptions on optics**

## Relative OOB Performance (<0.001 Req't):

Band Number	Band	CWL (nm)	Rel. Resp.
1	Coastal Aerosol	443	0.0002
3	Green	562	0.0003
4	Red	655	0.0004
9	Cirrus	1375	0.0004
7	SWIR-2	2200	0.0003

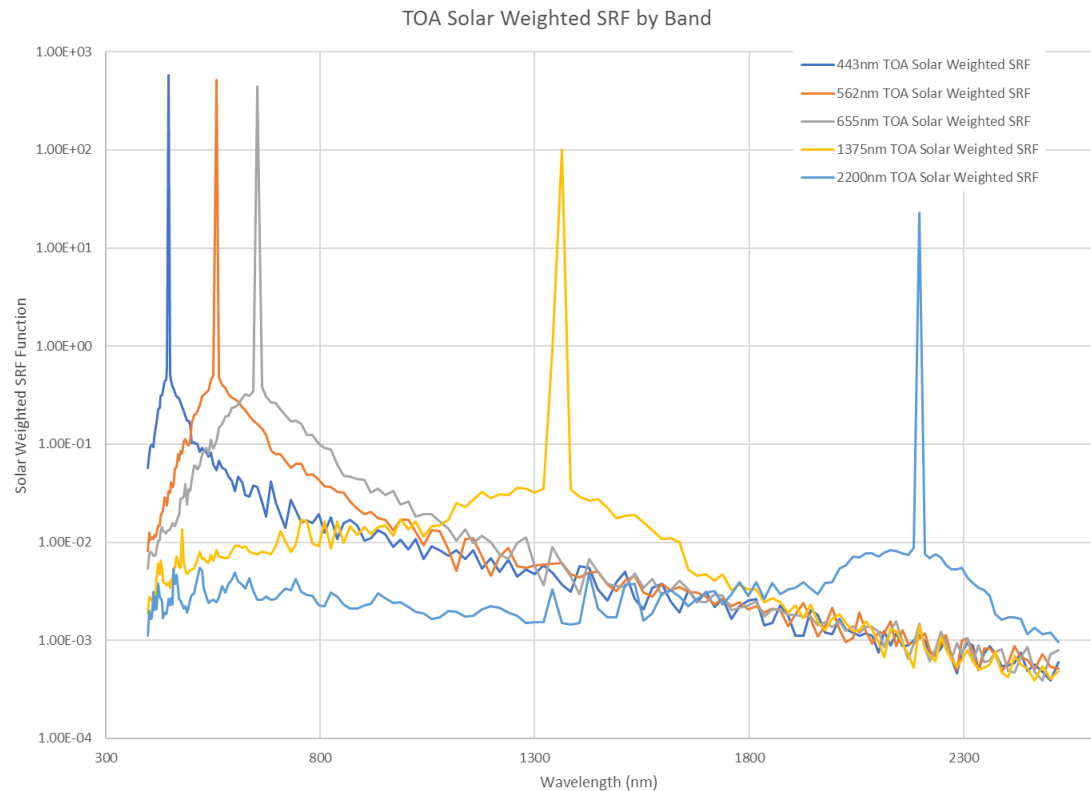

# Universal Hyperspectral Test Facility



- Test facility developed specifically for testing and characterizing imaging spectrometer performance
- Utilizes a Fabry-Petroy etalon to produce a comb of spectral features that are dispersed onto the FPA by the instrument under test
- Allows for simultaneous measurement of key performance parameters at multiple wavelengths
  - Spectral response function
  - Spectral smile
  - Keystone distortion
  - MTF
- Overcomes throughput limitations characteristic of monochromator-based approaches
- Functionality demonstrated from visible through LWIR (SIRAS-G, Project Guinness)

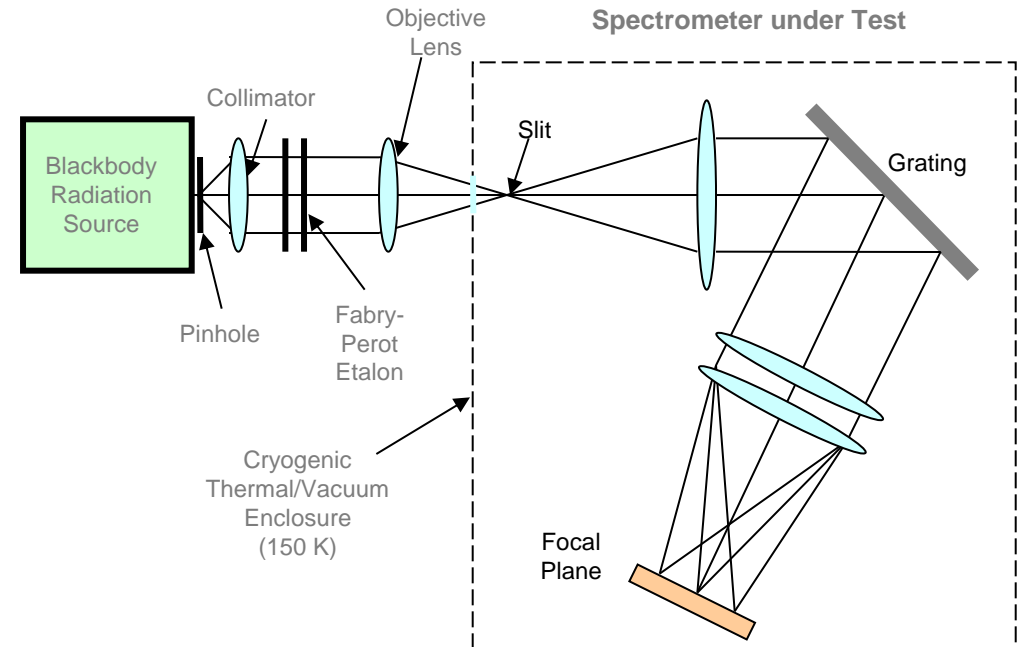

F-P Instrument Function as dispersed onto FPA by grating in spectrometer

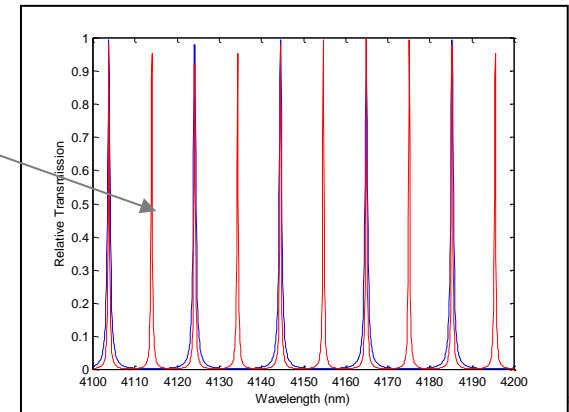

Technology developed under various Ball overhead and IRAD funds.  
US Patent 7,554,667, Method and Apparatus for Characterizing Hyperspectral Instruments, Kampe, T. U., (2009),  
Valle, et. al., "Efficient characterization of imaging spectrometers: application in the LWIR and MWIR," Proc. SPIE 7453, 754301 (2009) [doi: 10.1117/12.824627].

# Airborne Configuration



- Airborne demonstrations to be flown on De Havilland DHC-6 Twin Otter Aircraft with a large open nadir-viewing port
- Baseline co-manifest with REMI
- Instruments share the Applanix GPS-IMU but otherwise are functioning independently
- Requires one operator per instrument
- Engineering test flight in Year 2
- Vicarious calibration flight over uniform region (i.e., Railroad Valley, NV)
  - Timed to coincide with OLI overflight
  - Coincident ground-based measurements
- Overflights over diverse ecosystems in Year 3
  - Forested regions
  - Agricultural regions
  - Water bodies, coastline
  - Potential overflights of NEON sites

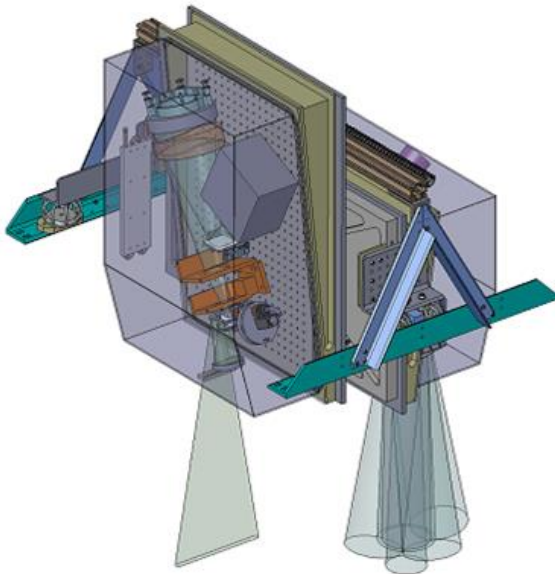

# Path to Space

- Spaceborne instrument concept development is on-going
- CHPS VSWIR imaging spectrometer with separate TIR instrument feasible within volume approaching *Reduced Instrument Volume Requirement*
  - 0.5 m cube
- Radiometric Math Model adapted to spaceborne system
  - SLI-T CHPS Flight Concept Meets SNR Requirements at the Binned RMA Bands and at Nearly All Single-Pixel Wavelengths

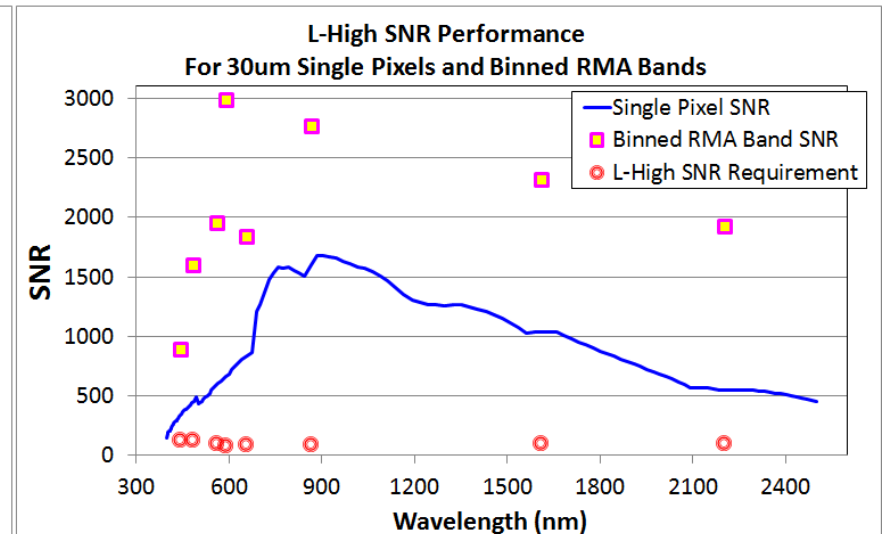
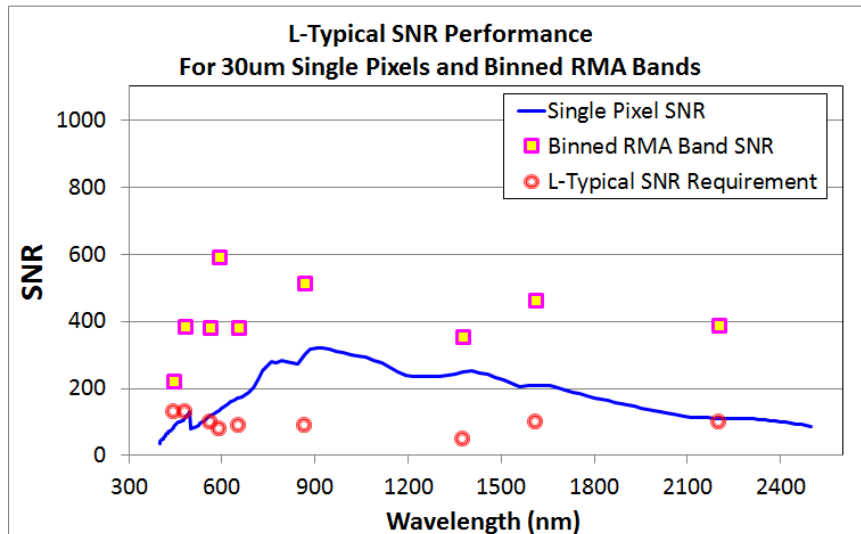



# Project Timeline



2017  
Design &  
Development

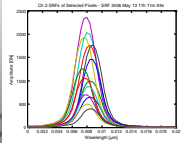

2017Q4  
Laboratory  
Testing

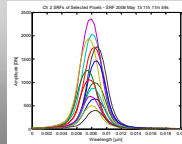

2018 Q1/2  
Eng. Flight  
Campaign



2018 Q3/4  
Data Flight  
VSWIR Bands



2019 Q2/3  
Science  
Flights



- Spectrometer characterization Spectral response function, smile; keystone distortion, dispersion
- Heliostat Solar source provides realistic spectral profile & opportunity for direct comparison between CHPS SLIT and OLI-2

- Eng. Flights ensure proper interfacing and functionality while airborne
- Data Flights used to generate data, data format, & initial L2 data products
- Science Flights used to acquire data of specific interest to the science community

# Conclusion & Acknowledgements



- **Airborne instrument on track for completion by year-end 2017**
- **Airborne flight campaigns planned**
  - **Initial engineering flight data by spring 2018**
- **Will be looking to coordinate data product development with science team**
  
- **Acknowledgements**
  - **This project funded by the NASA Earth Science Technology Office, Grant NNX16AP61G**