

Snow and Water Imaging Spectrometer (SWIS): development of a CubeSat-compatible instrument

Pantazis Mouroulis, Holly Bender, Christopher D. Smith^a, Johannes Gross,
Thomas Painter, Colin H. Smith, Daniel W. Wilson, Byron E. Van Gorp,
Michael L. Eastwood, Justin Haag, Steve Ackleson^b, Heidi Dierssen^c,
Victor White, Karl Yee

Jet Propulsion Laboratory, California Institute of Technology, Pasadena, CA

^aSierra Lobo Inc., Pasadena, CA

^b Naval Research Laboratory, Washington, D.C.

^cUniversity of Connecticut

ESTF 2016

Overview

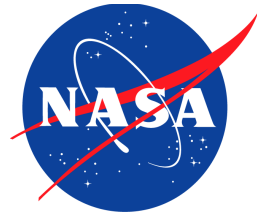

- Research and applications for a CubeSat – compatible imaging spectrometer
- Instrument specifications
- Mission concepts
 - Global access (6 CubeSats)
 - Targeted areas (1 CubeSat)
- Optomechanical design
- Calibration mechanism
- CubeSat configuration
- Current status and work to go

Goal: demonstrate the potential utility of CubeSats to make useful scientific contributions in imaging spectroscopy

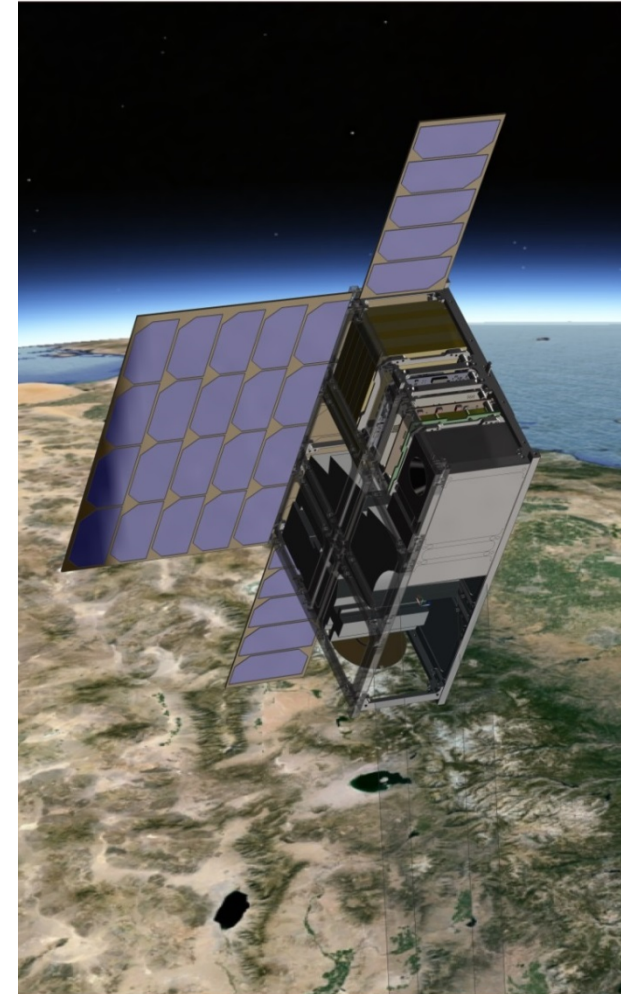

SWIS CubeSat, artist's concept

Introduction

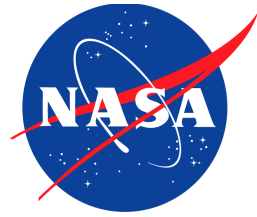

- Imaging spectrometer heritage at JPL: AVIRIS, MaRS, AVIRISng, CAO, NIS, PRISM, M3
- CubeSats:
 - More frequent/regular sampling relative to airborne
 - Intermediate to high resolution relative to global or flagship missions
 - Relatively low-cost alternative
- To stay within CubeSat resources:
 - No cryogenic temperatures (limits wavelength range)
 - Low data volume and rate (limits area coverage to specific target areas)
 - Telescope aperture constrained by volume

CubeSat platform particularly well-suited for two critical niche applications: **coastal ocean** science and **snow cover** monitoring

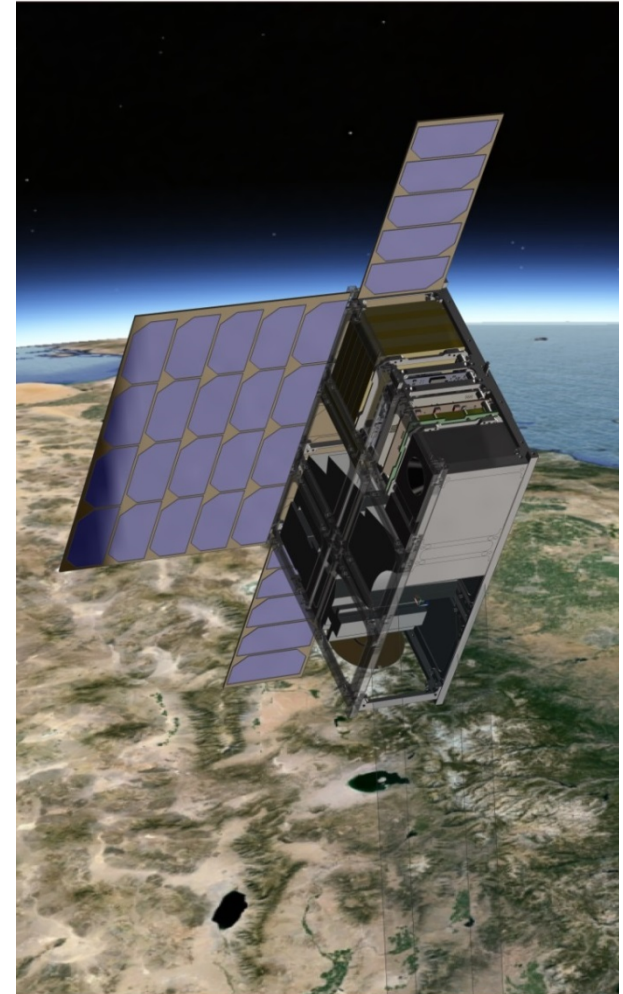

SWIS CubeSat, artist's concept

Research and applications

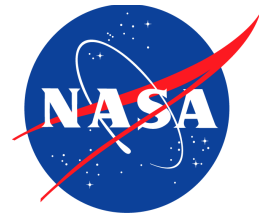

Coastal science: Complex spectral signatures from the coastal environment demonstrate that heritage multi-spectral sensors are inadequate

- High temporal variability makes consistent airborne monitoring costly
- High spatial variability requires higher resolution than heritage sensors

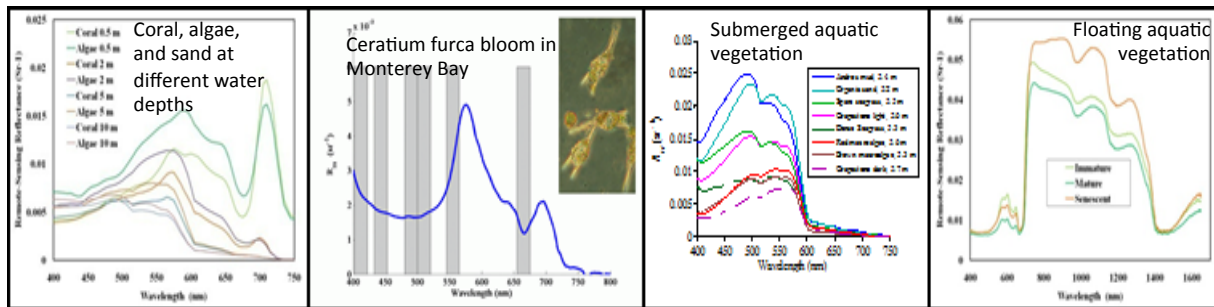

Coastal ocean spectral signatures mainly **below 900 nm**

Snow cover: Spectral signatures of snow in various states demonstrate the utility of spectroscopy in understanding energy transfer and hydrology

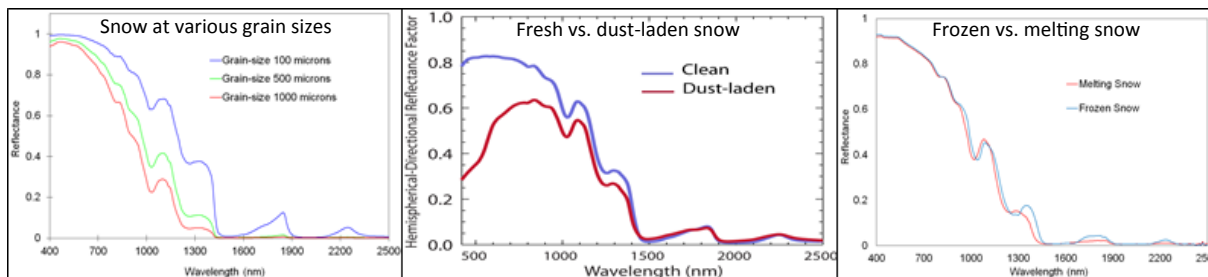

Snow spectral signatures contain critical features in **1000-1500 nm** range

Instrument specifications

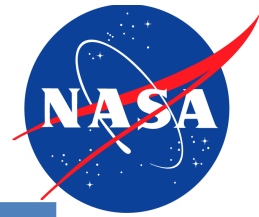

Spectrometer and telescope inside 6U CubeSat frame

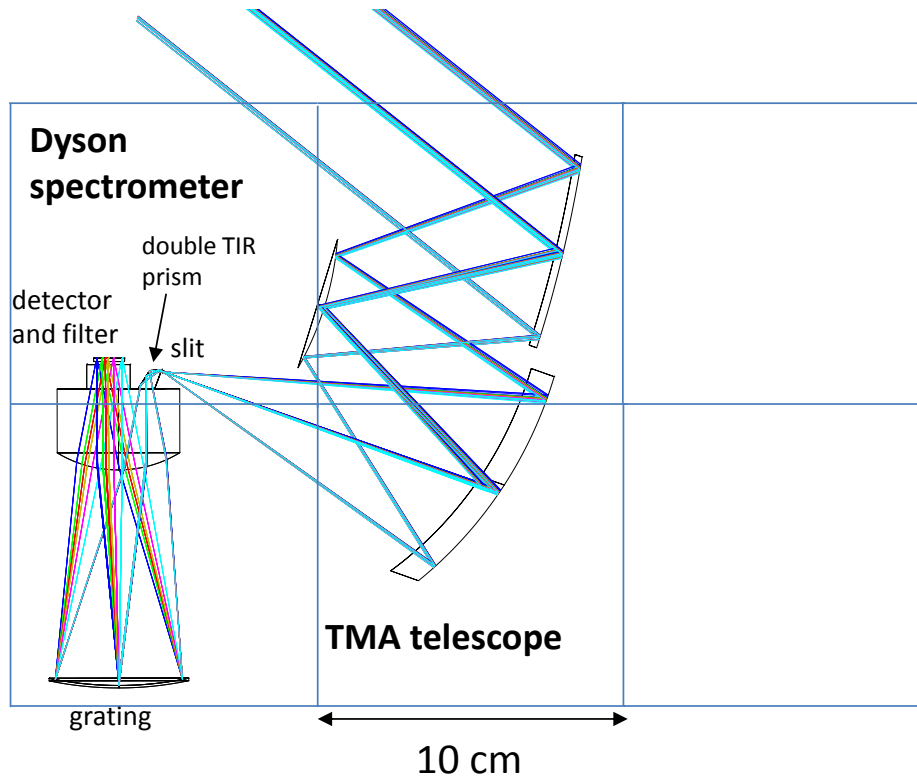

Mouroulis et al, Proc. SPIE 9222, (2014)

SWIS specifications

Spectral range	350-1700 nm, single FPA
Spectral sampling	5.7 nm
Cross-track spatial elements	600 (+40 monitor)
Cross-track FOV	10°
Resolution	0.3 mrad
Detector pixel size	30 μm
Focal length	100 mm
F-no	1.8
Uniformity	95%

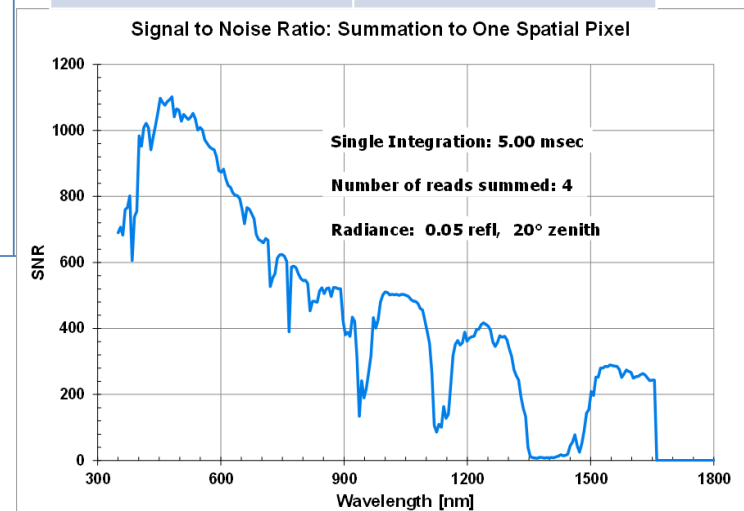

Mission example: Global access

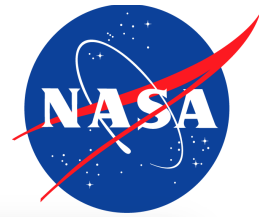

SWIS: Global access (6 CubeSats)

Resolution	160m from 500km orbit
Swath	640 spatial elements
Mission lifetime	~2 years (no propulsion)
Target frequency	Global daily coverage with 6 CubeSats
Application	Coasts, snow cover

*Global coverage at low (~1 km) resolution subject to future data transmission rate improvements

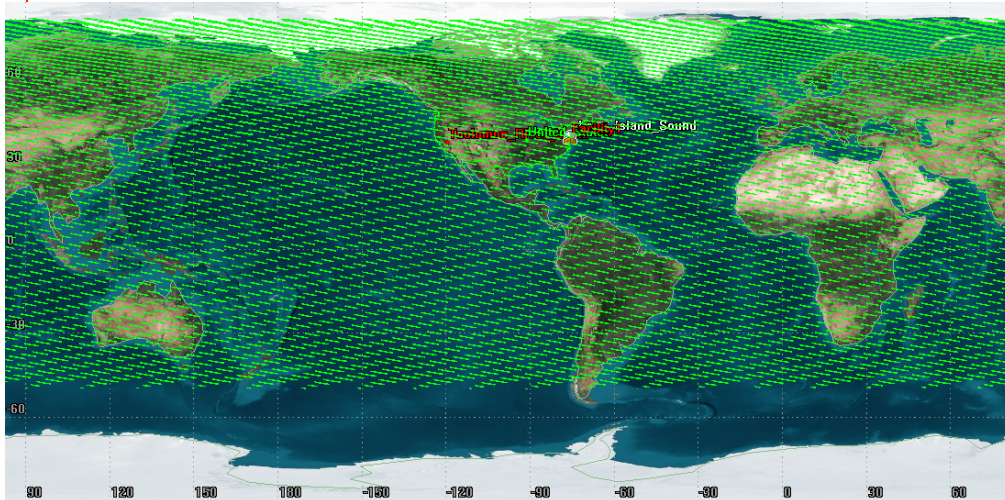
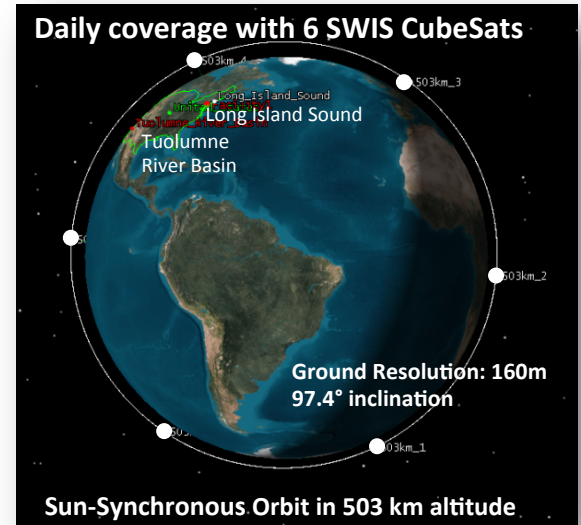

To access any point on the globe on a given day:

- 6 CubeSats, 500 km orbit
- 10° Field of view
- 50° Field of regard with pointing

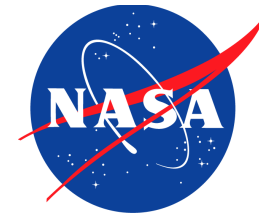

Mission example: Global access

Coverage of Tuolumne River Basin (snow)
and Long Island Sound (water)

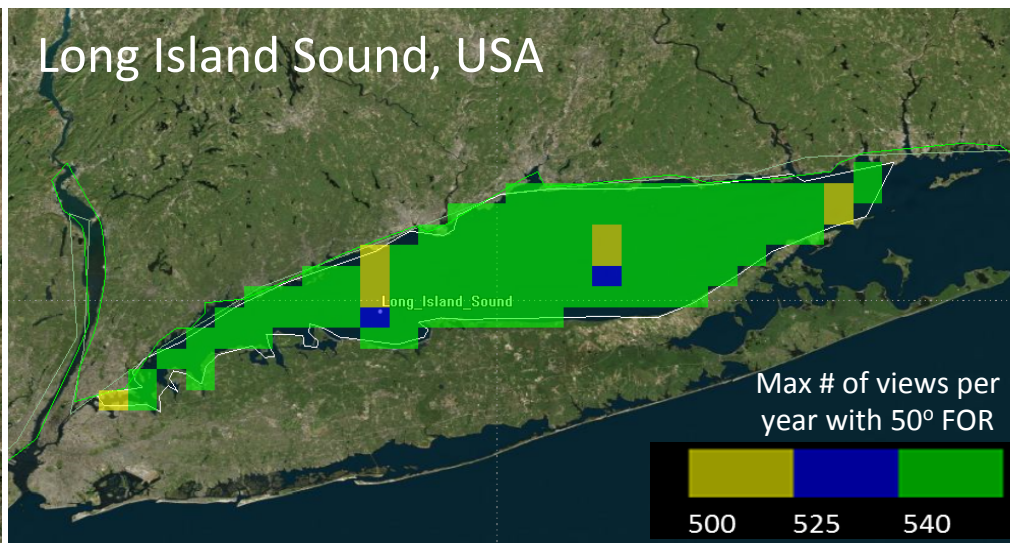
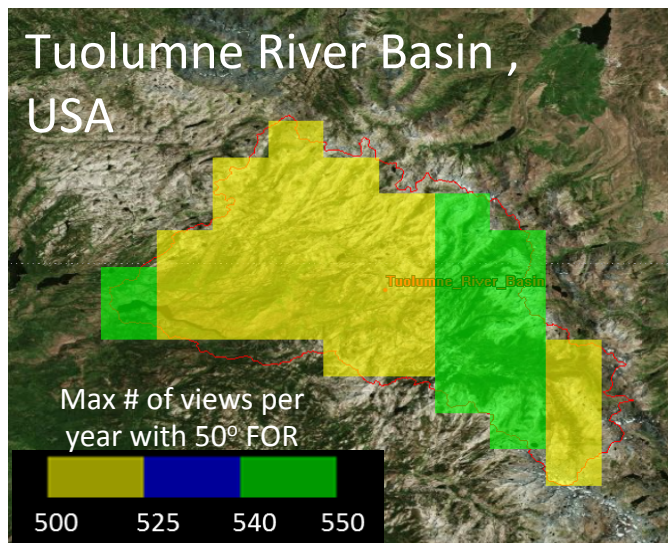

Maximum number of views per year with 50° FOR
Over 100 views obtained for both cases without pointing (10° FOV)
6 CubeSats at 500km orbit

- Episodic events can be covered with better than daily frequency

Seasonal and interannual variability in aquatic photosynthetic communities (phytoplankton, macrophytes, and coral) as a function of environmental stress due to human activities and climate change.

High SNR spectra from target regions of interest

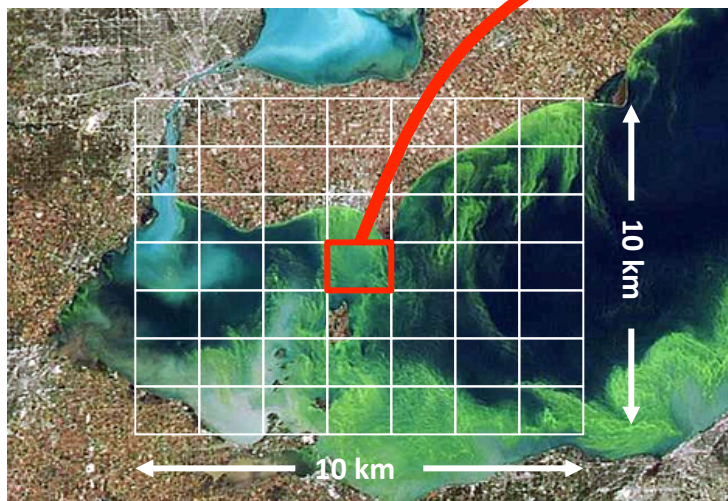

Repeat measurements of highly accurate spectrometry and focused spatial coverage from aquatic environments inverted for key ecological attributes to yield change rate and high-frequency variability.

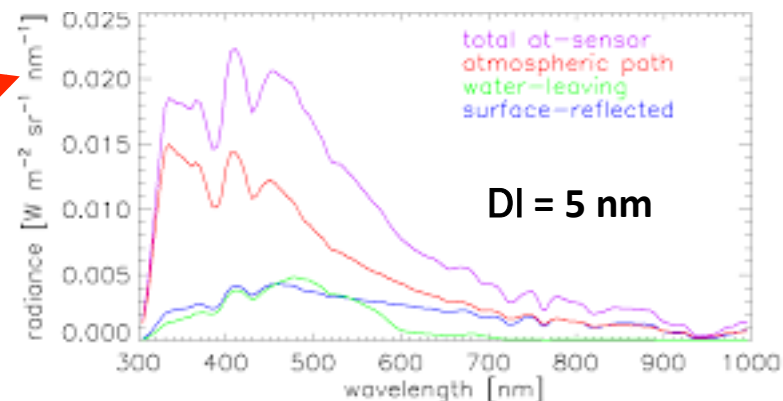

Atmospheric Correction
(Water-Leaving Radiance Signal, R_w)

Spectral Deconvolution of R_w

$$(R_w = W_1 * R_1 + W_2 * R_2 + \dots + W_N * R_N)$$

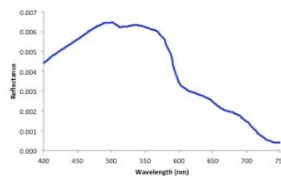

Water Constituent 1

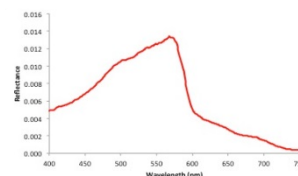

Water Constituent 2

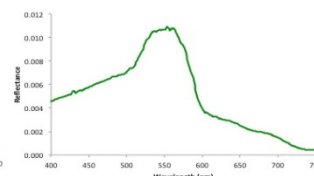

Water Constituent 3

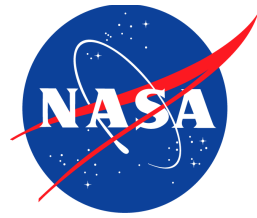

SWIS satisfies mission requirements

- **High spectral resolution** for detecting subtle changes in the spectral signature of aquatic habitats.
- **High radiometric sensitivity / SNR** to tease out subtle spectral features from on-orbit radiance dominated by the intervening atmosphere.
- **Near IR spectral coverage** for discriminating between atmospheric and surface water signatures.
- **High spatial resolution** to limit spectral mixing and resolve signals from ecologically important features.
- **Maneuverability** for viewing off-nadir targets and higher repeat coverage of key locations.
- **Calibration** using solar radiance and lunar views.

Science Objectives

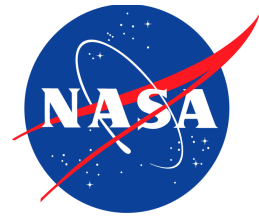

How is phytoplankton taxonomy changing?

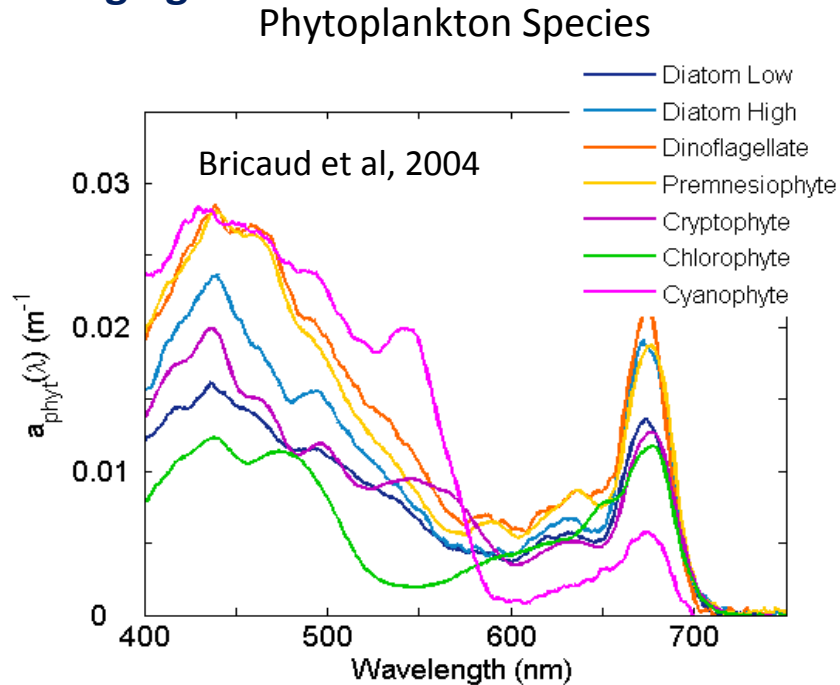

Emerging spectral analysis techniques can detect subtle changes in phytoplankton community structure from hyperspectral water reflectance.

What is the carbon export from benthic macrophyte communities?

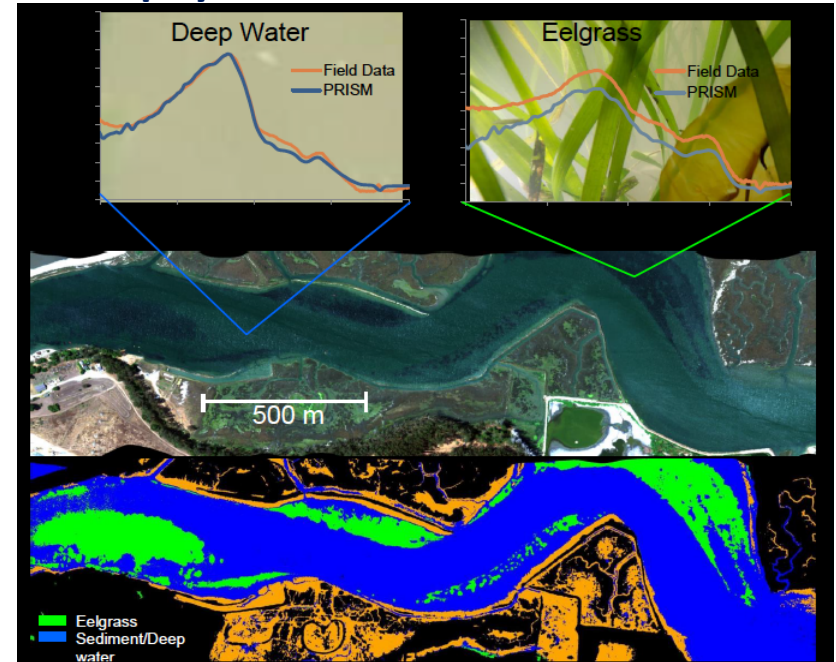

Dierssen, H. M. 2012. SPIE, San Diego, CA

- Submerged grass meadow detection demonstrated from airborne measurements and in-situ verification
- Biomass production/export estimation

Mission example: Targeted regions of interest

Spectroscopy of glacier melt and impact to aquatic environment

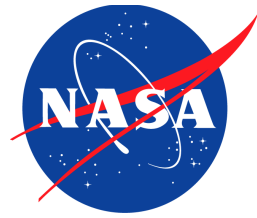

Can a single CubeSat provide adequate coverage for meaningful science?

Yes. In certain targeted regions of interest.

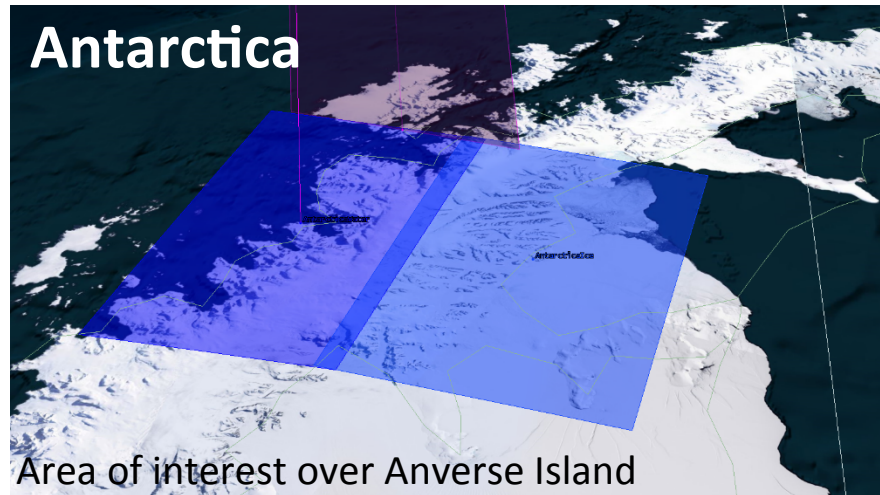
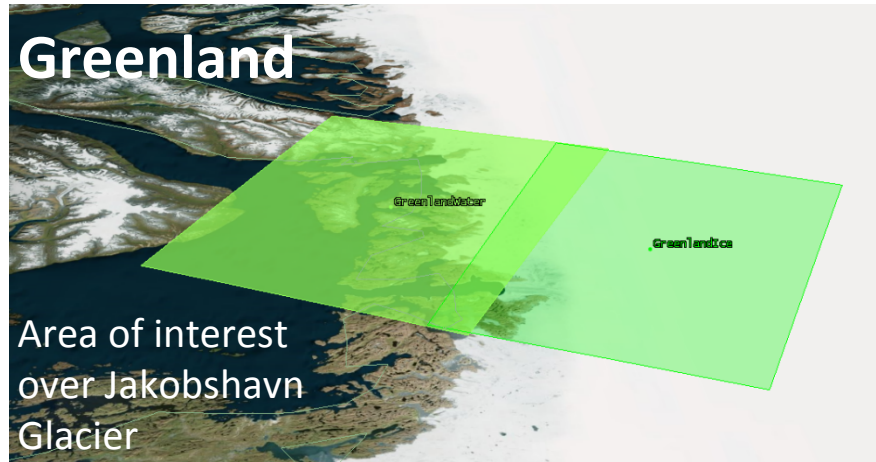

- The SWIS spectrometer design can **simultaneously map the controlling processes of melt and the response of ocean biology** to melt fluxes and nutrient loading.
- Gradients from dry snow, to melting snow and ice, to melt-fed open ocean **span the most critical zones of climate change-impacted regions.**

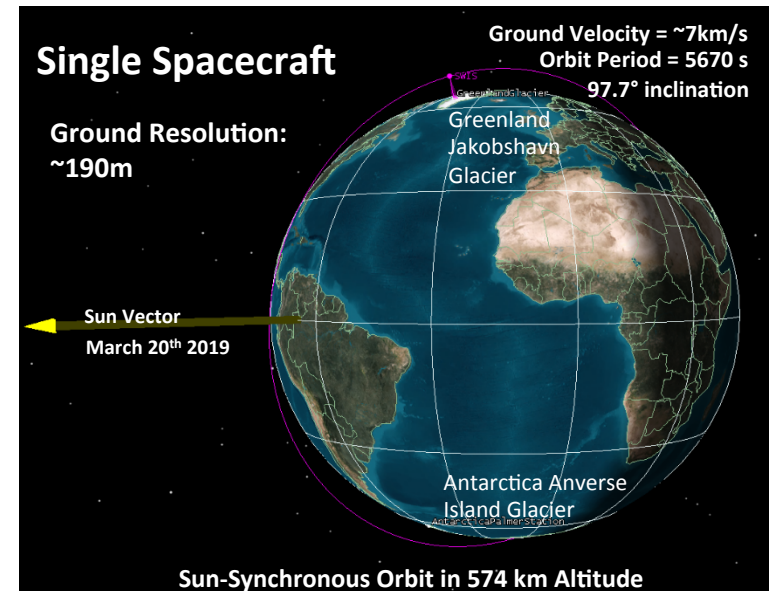

Orbit simulation for single CubeSat in sun-synchronous orbit at 574km

Mission example: Targeted regions of interest

Spectroscopy of glacier melt and impact to aquatic environment

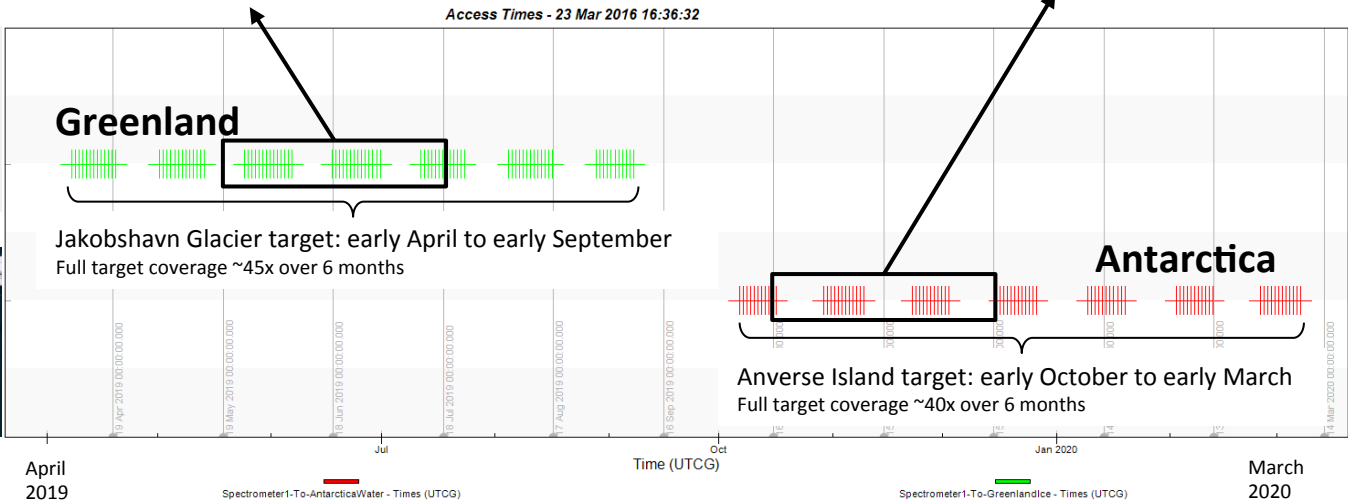
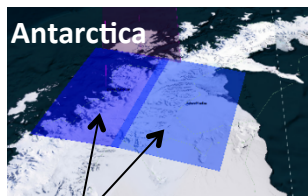
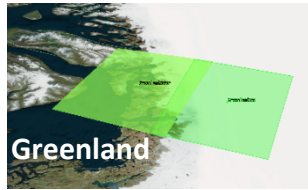
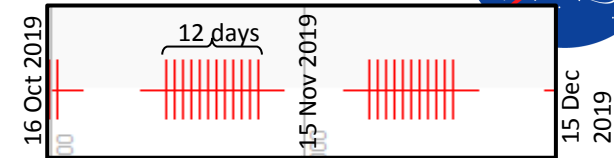
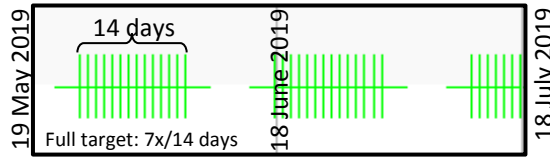
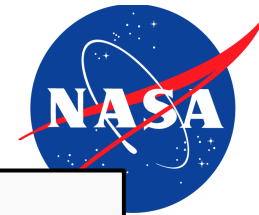

Full target area coverage by alternating between the two adjacent patches on consecutive days

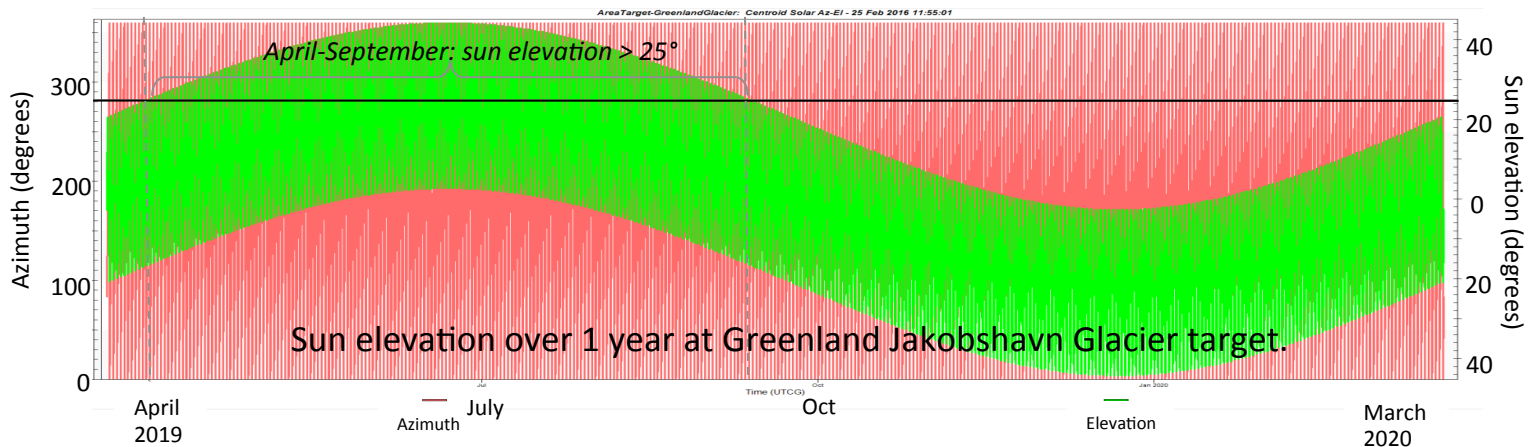

Optomechanical design

Dyson Spectrometer and TMA telescope fit in 4U of 6U CubeSat

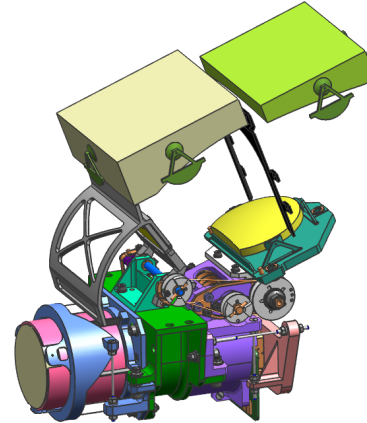
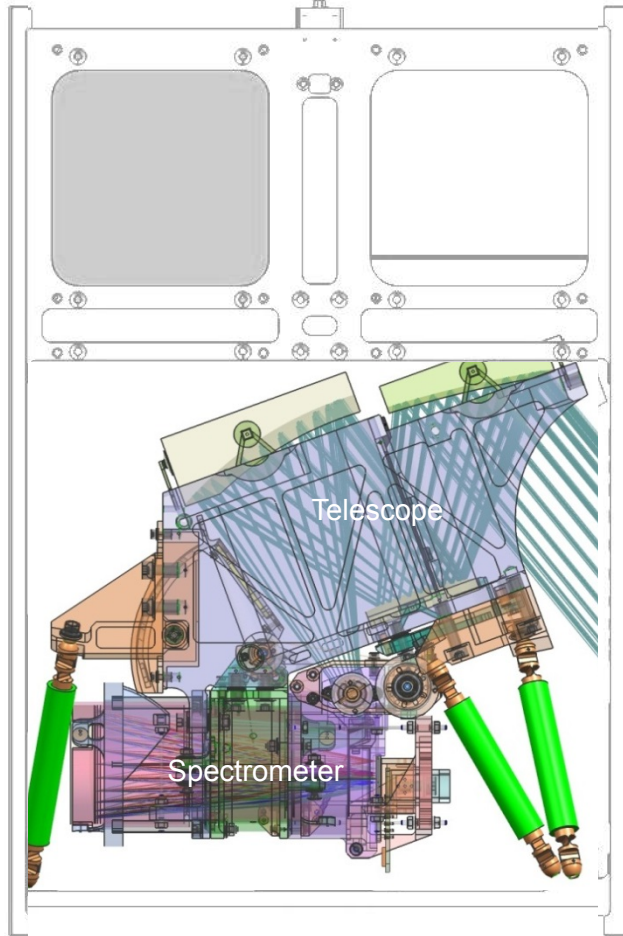

SWIS optomechanical system (bipods and telescope housing hidden)

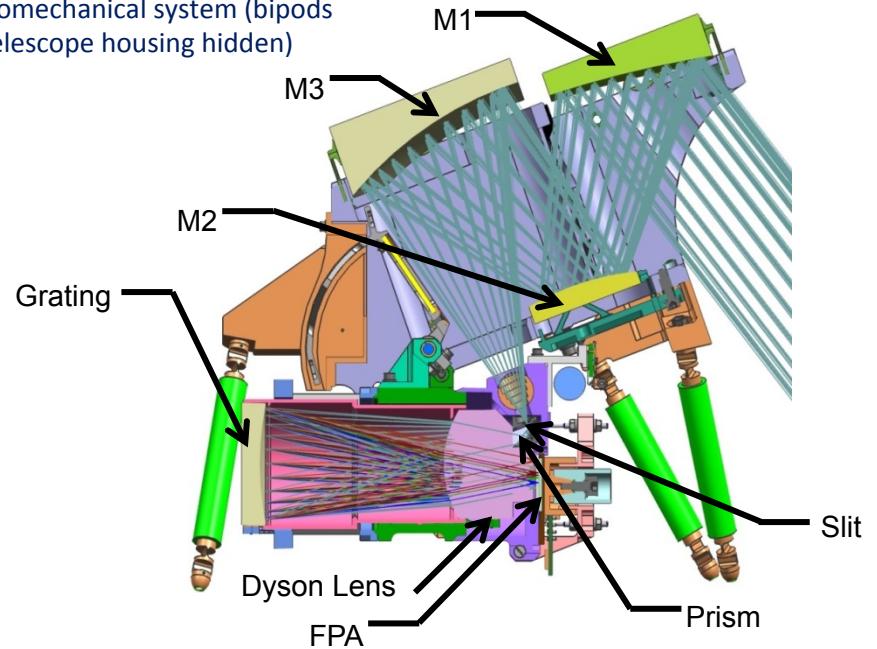

Bender et al, Proc. SPIE 9611, Imaging Spectrometry XX (2015)

Calibration mechanism

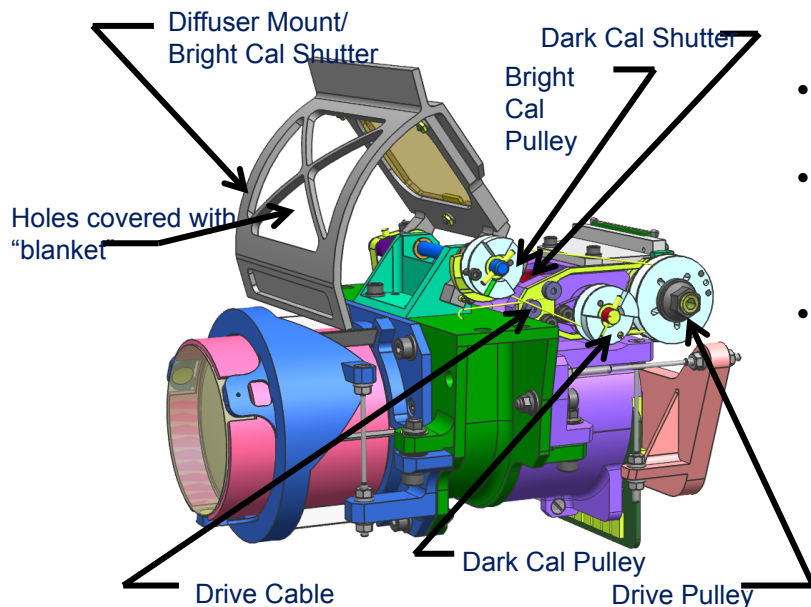

- Imaging spectroscopy requires stringent radiometric calibration accuracy
- Single drive mechanism performs the dual function of positioning the on-board calibrator (OBC) and providing a shutter for dark frames.
- Solar calibration achieved using a transmissive diffuser material (Heraeus OM-100).

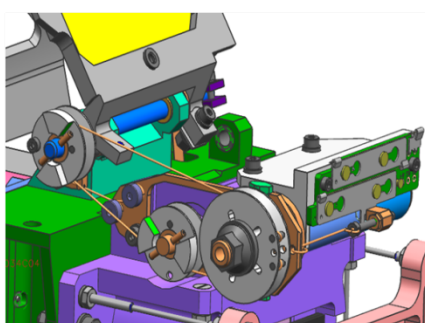
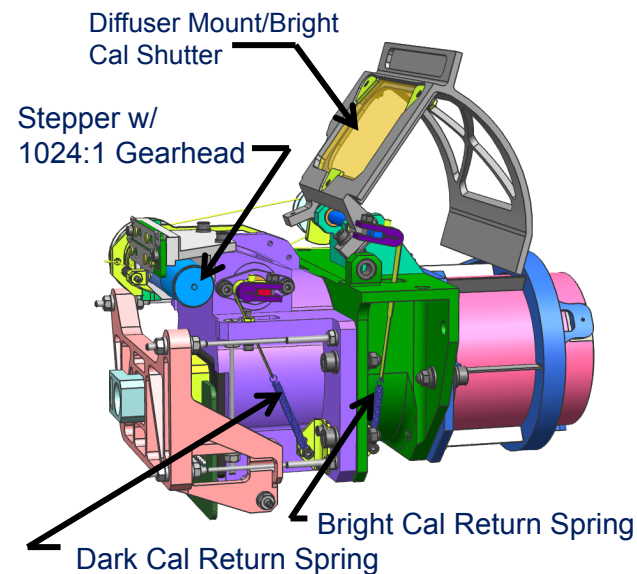

Calibrator Drive Mechanism



Bright Cal Light Path

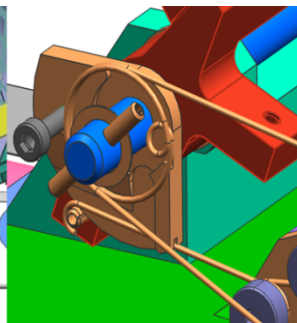

Launch Latch



Dark cal shutter

A Dyneema drive cable operates in tension against a return spring (*left*), actuating bright and dark calibrators. In the solar calibration position (*center*), the diffuser mount blocks signal from the telescope. A dark calibration shutter rotates to a closed position for darks. The mechanism also includes a launch latch (*right*) released on first usage, and a fail-safe.

SWIS 6U CubeSat configuration concept

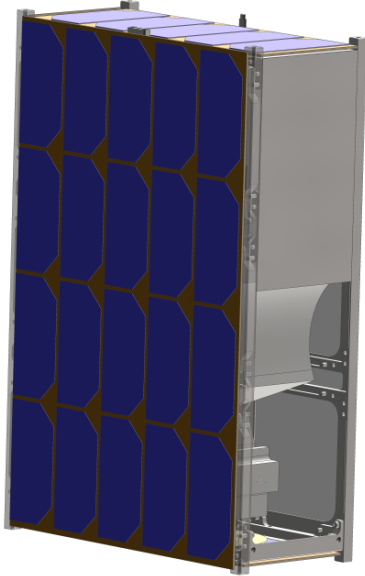
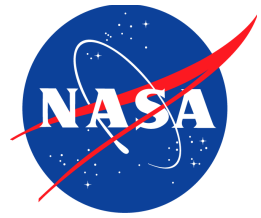

Solar panels stowed configuration

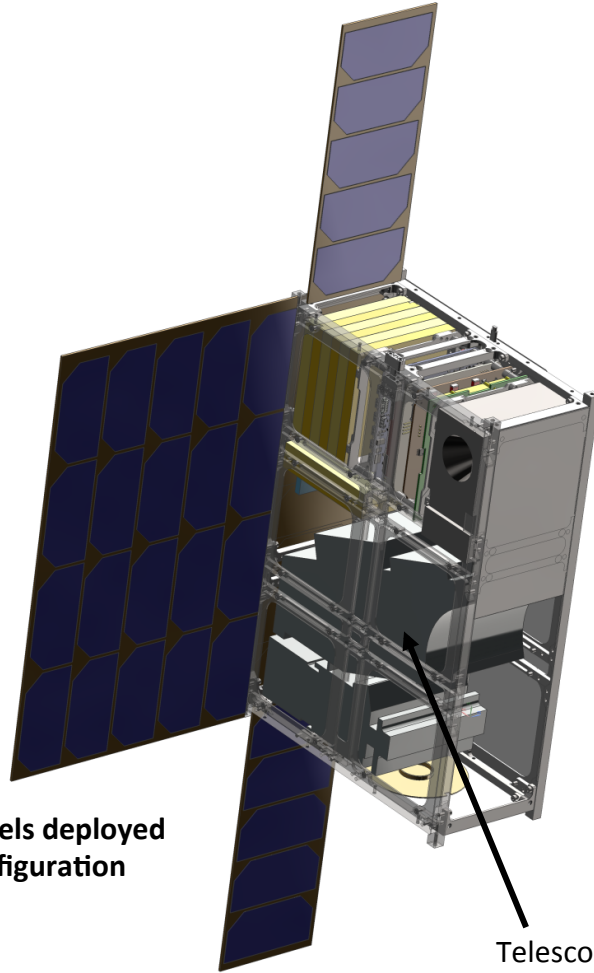

Panels deployed configuration

Telescope and spectrometer within 4U of 6U CubeSat

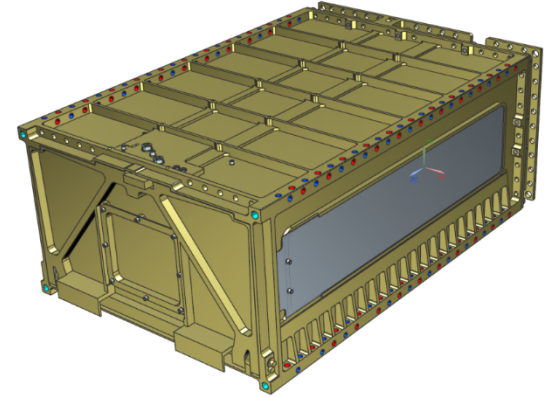

Spacecraft designed to fit within a standard 6U Canisterized Satellite Dispenser (current: Planetary Systems Corporation)

SWIS 6U CubeSat configuration concept

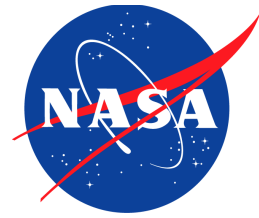

Components identified and designed specifically to fit within a standard 6U satellite dispenser.

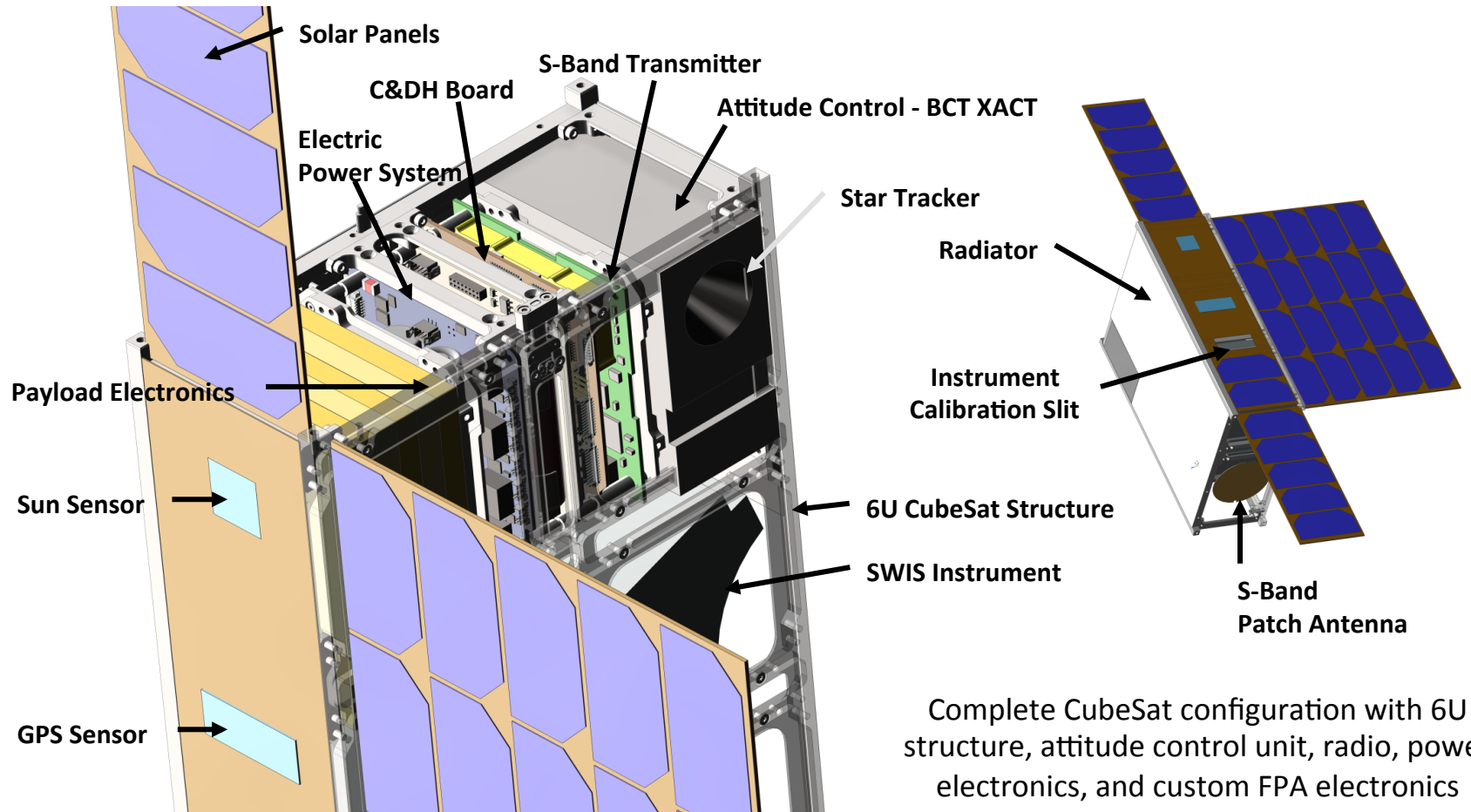

The current SWIS design has a good feasibility within a flexible CubeSat standard.

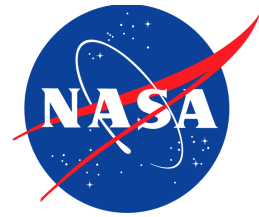

Status and work to go

- Optics and optomechanical parts fabrication complete
- Initial optomechanical assembly of telescope and spectrometer underway
- Teledyne CHROMA detector array expected summer 2016
- Complete optomechanical system assembly and alignment scheduled for Fall 2016
- Thermal vacuum and vibration testing completion: March 2017

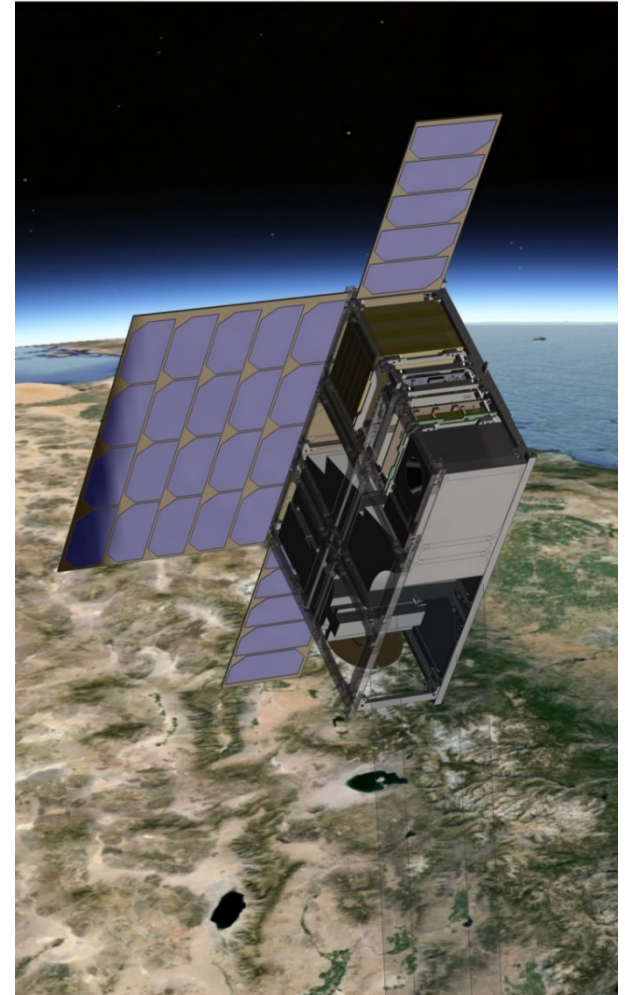

SWIS CubeSat, artist's concept

Diffraction grating fabricated and tested

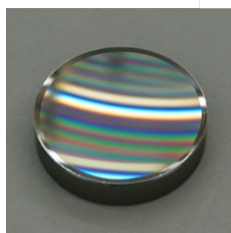

SWIGS diffraction grating

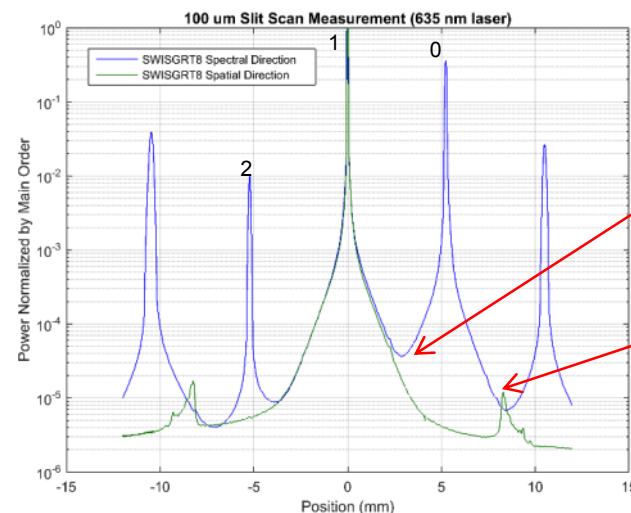
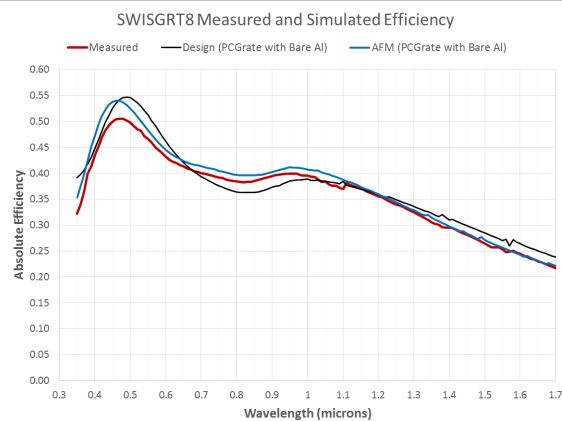
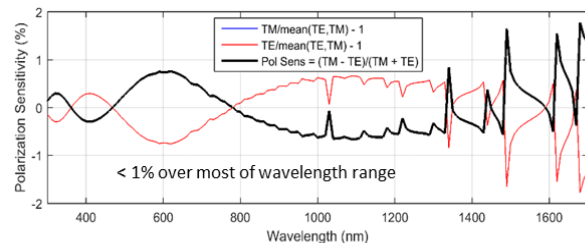
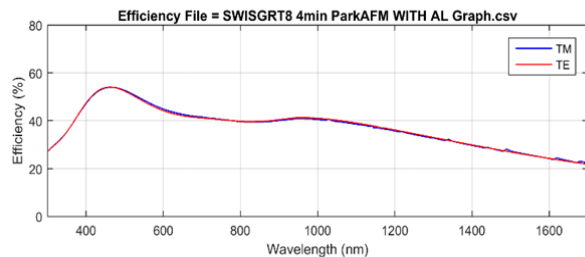

< 10^{-4} between orders - excellent

Spatial ghosts due to e-beam subfield stitching << 10^{-4} - excellent

Slit fabrication

- Slit delivered December 2015
- New fabrication process for black silicon slit
 - Removes “canyon” and completely removes residual gold reflectivity

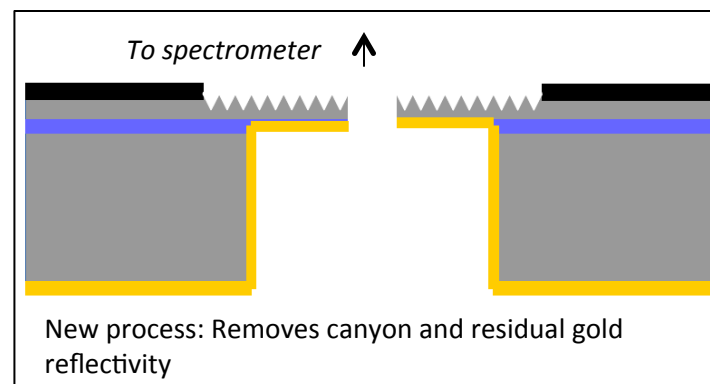
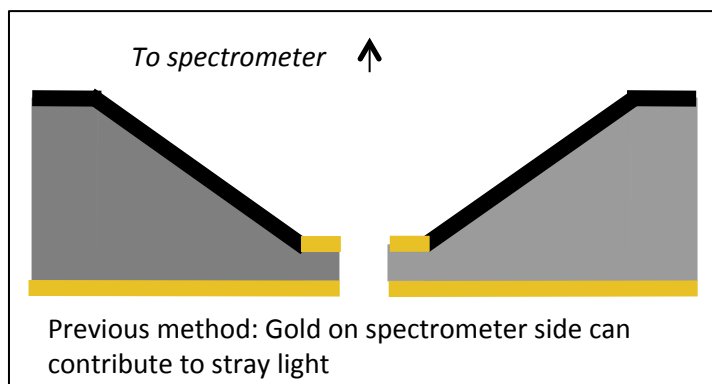

SEM images of SWIS black silicon slit (#12_14_15_1)

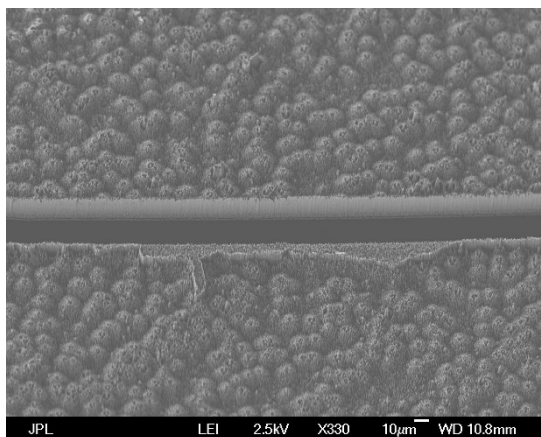

Angle 30°, magnification 330x

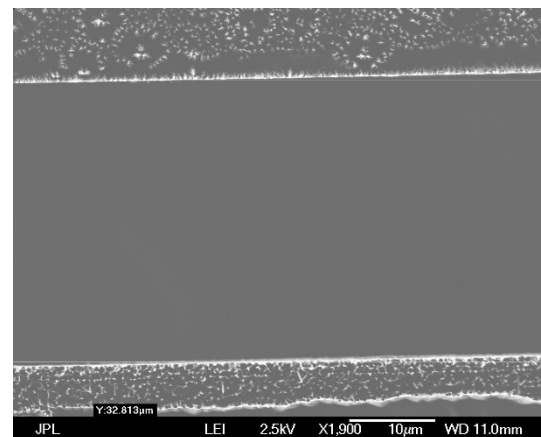

Angle 0°, magnification 1900x

Lens/slit geometry and stray light test

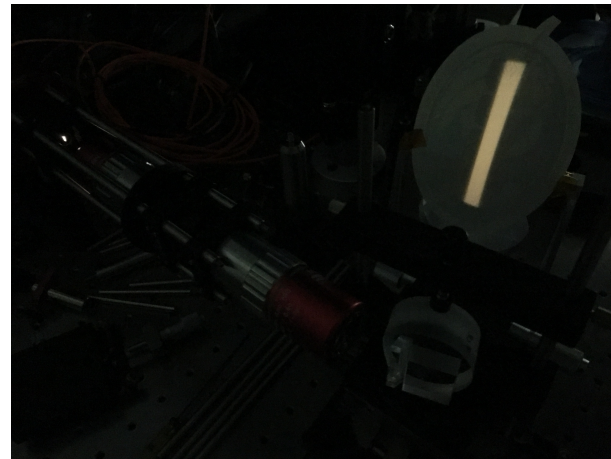
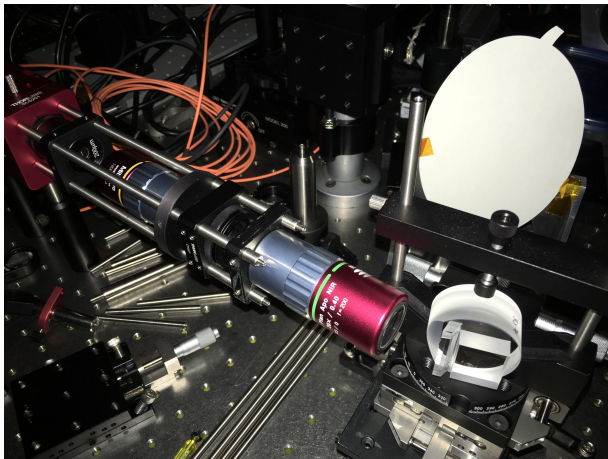
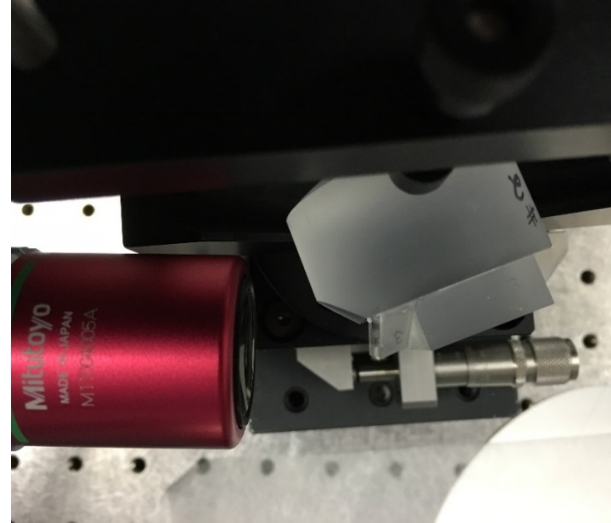
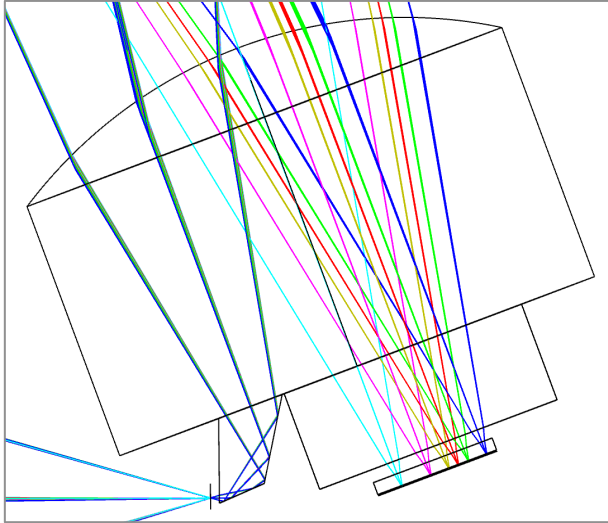

FPA progress (Teledyne Imaging Sensors)

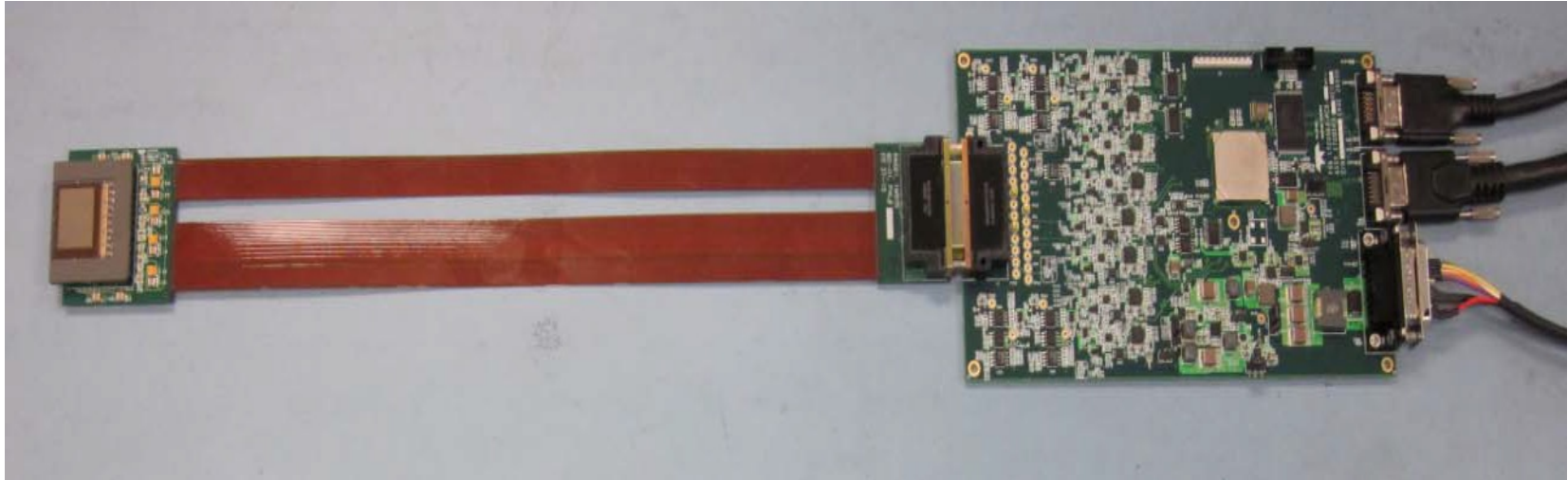

- Flex cable tested and delivered
- FP electronics delivered, undergoing evaluation
- Bare ROIC delivered
- Detector material tested and found to satisfy dark current requirements
- Thinning completed

Remaining:

- Complete assembly and apply LVAR coating. Expected delivery July 2016.

Assembly started

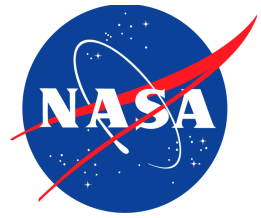

Telescope bench

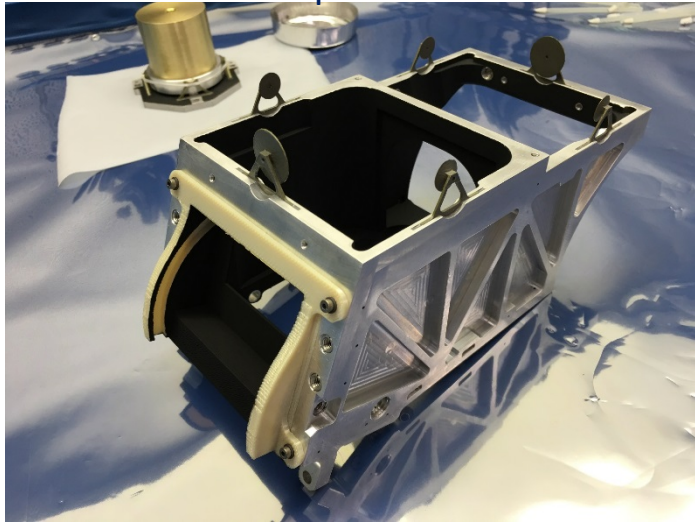

Secondary mount

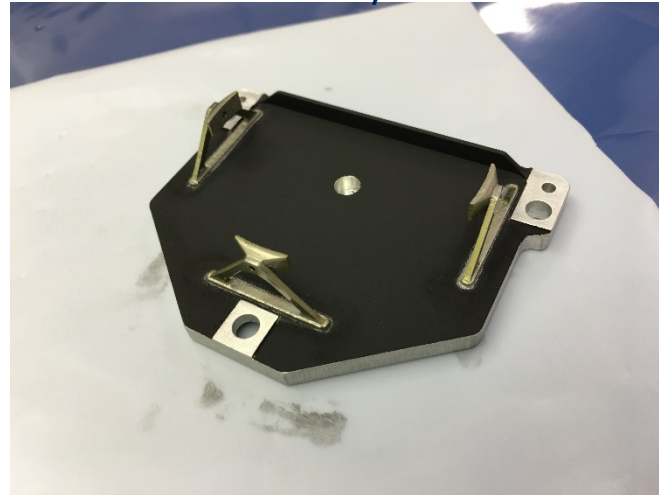

Mirror alignment GSE

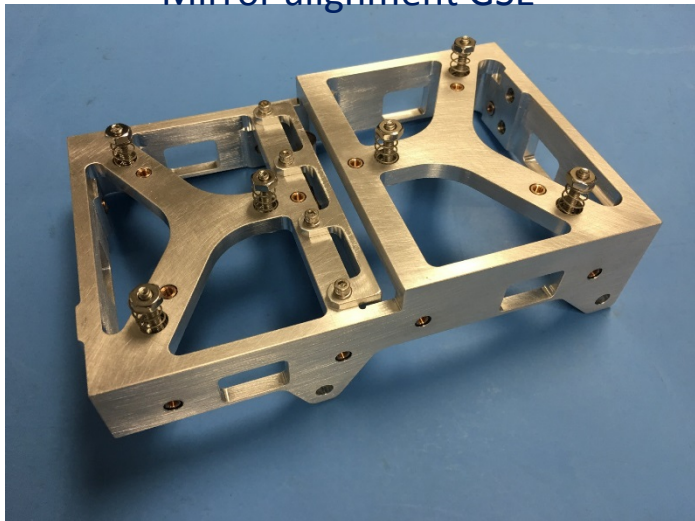

Temporary setback

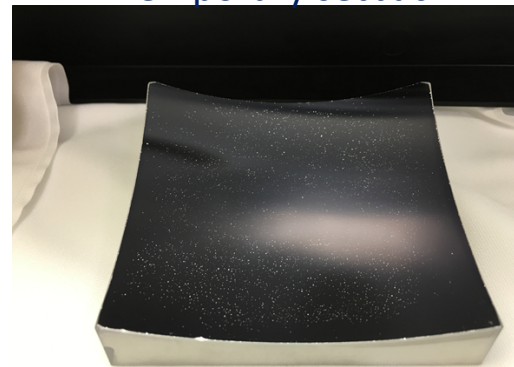

Summary

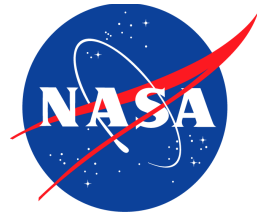

- We present an imaging spectrometer design suitable for CubeSat applications requiring high throughput (SNR)
- Advances the state of the art in compact sensors of this kind in terms of size and spectral coverage
- Innovative single drive performs dual mechanism function of positioning the on-board calibrator (OBC) as well as providing a shutter for dark frames
- Spacecraft configuration design favorable for accommodation in 6U CubeSat frame
- Useful missions can be designed with high spatial and temporal resolution to address targeted areas of the Earth's surface
- Progress consistent with project schedule and milestones

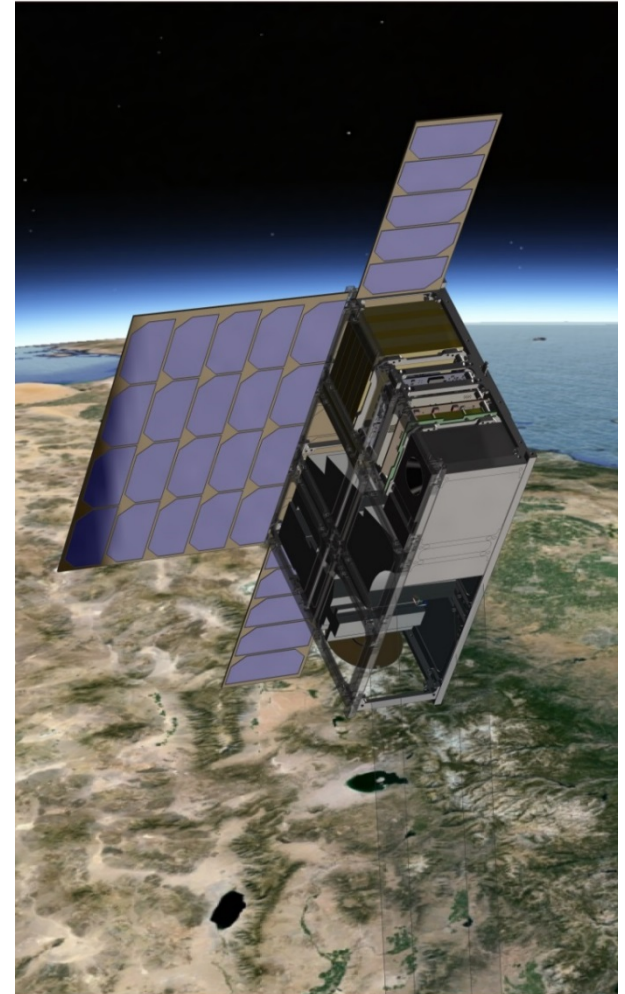

SWIS CubeSat, artist's concept

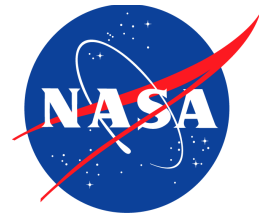

Acknowledgments

The SWIS Project Team:

PI: Pantazis Mouroulis

Task Manager: Holly Bender

Co-Is: Rob Green, Tom Painter, Heidi Dierssen (*University of Connecticut*), Byron Van Gorp, Dan Wilson, Michael Eastwood, Jose Rodriguez

Engineering Team: Christopher Smith (*Sierra Lobo, Inc*), Johannes Gross, Dan Preston, Colin Smith, Paula Pingree, Elliott Liggett, Ernesto Diaz

Science Collaborator: Steve Ackleson, NRL

Industrial Partner: Teledyne Scientific & Imaging (Jianmei Pan, task manager)