

Next Generation UAS Based Spectral Systems for Environmental Monitoring

P. Campbell^{a, b}, P. Townsend^c, D. Mandl^b, C. Kingdon^c, V. Ly^b, R. Sohlberg^d, L. Corp^b, L. Ong^b, P. Cappelaere^b, S. Frye^b, M. Handy^b, J. Nagol^d, V. Ambrosia^e, and F. Navarro^c

^a University of Maryland at Baltimore County, Catonsville, MD

^b NASA/Goddard Space Flight Center, Greenbelt, MD

^c University of Wisconsin, Maddison, WI

^d University of Maryland, College Park, MD

^e California State University, Monterey Bay, CA

June 23-25, 2015
CalTech Pasadena, CA



Scales at which remote sensing spectral measurements are currently made with gap

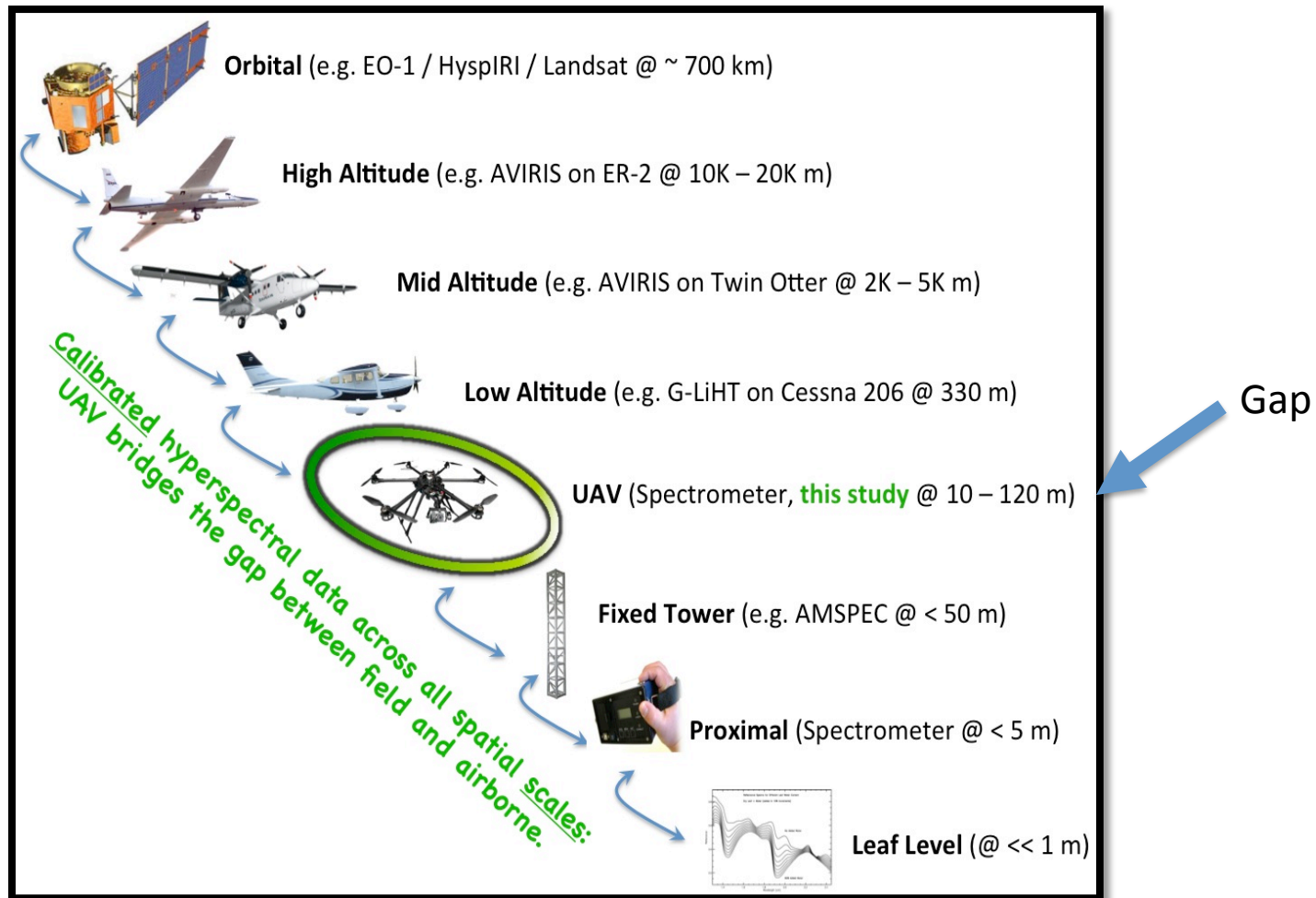

Unmanned Serial System (UAS) sensors are bridging the gap between ground and higher altitude aircraft data.

Basic Components



3DR Pixhawk

- Advanced autopilot
- 32 bit ARM Cortex M4 processor
- NuttX RTOS



Ocean Optics USB 2000+UV-VIS

- Miniature spectrometer pre-configured for general UV-VIS measurements
- Covering a wide wavelength range, from 200 to 850 nm

Basic Components

Piccolo Doppio QE Pro

- Any two USB controlled spectrometers
- Spectrometers log simultaneously
- Can add external cooling to uncooled spectrometers if required
- Weight (with QE Pro) ~2.0kg

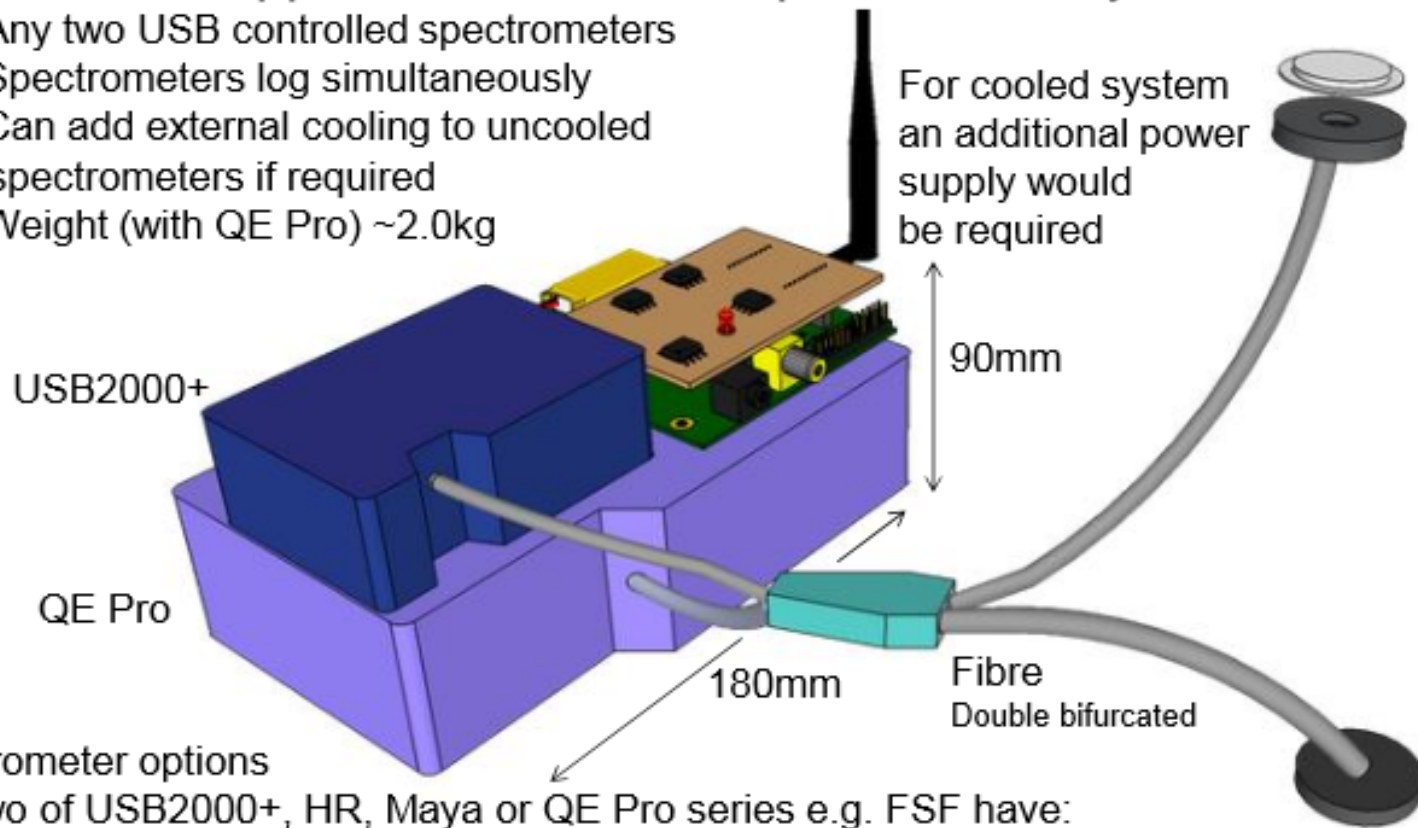

Spectrometer options

Any two of USB2000+, HR, Maya or QE Pro series e.g. FSF have:

Basic Components

Headwall Nano-Hyperspec



- 640 spatial bands
- 270 spectral bands
- ~2.2nm spectral sampling interval
- 5nm spectral resolution (FWHM with 20-micron slit)
- 17mm lens
- 480GB storage capacity (~ 130 minutes at 100 fps)
- Connectivity: Gigabit Ethernet
- Size (exclusive of GPS): 3" x 3" x 4.72" (76.2mm x 76.2mm x 119.92mm)
- Weight: less than 1.5 lb. (0.68kg)

Intelligent Payload Module (IPM)



- MicroZed Z-7020 Board
 - 2 ARMS
 - 50,000+ FPGA gates
- SensorWeb flight and ground software

PROJECT GOALS

- Goal is to produce in 2 years (June 2015 – May 2017) science-quality spectral data from UAS suitable for scaling ground measurements and comparison against airborne or satellite sensors.
- We will develop protocols and a workflow to ensure that Visible and Near Infra-Red(VNIR) measurements from UAS's are collected and processed in a fashion that allows ready integration or comparison to NASA satellite and airborne data and derived products (e.g. Landsat, AVIRIS EO-1 Hyperion and future HypIRI).

Objectives

Develop the UAS capability to:

- Retrieve biochemical and physiological traits
- Depict diurnal and seasonal cycles in vegetation function,
- Optimize UAS spectral data acquisition and workflows, to develop a small UAS hyperspectral using SensorWeb components
- Produce science-quality spectral data and biophysical parameters (BP), suitable for scaling ground measurements and comparison to from-orbit data products.

Technology/Measurements

a) USB 2000 and Headwall spectral range

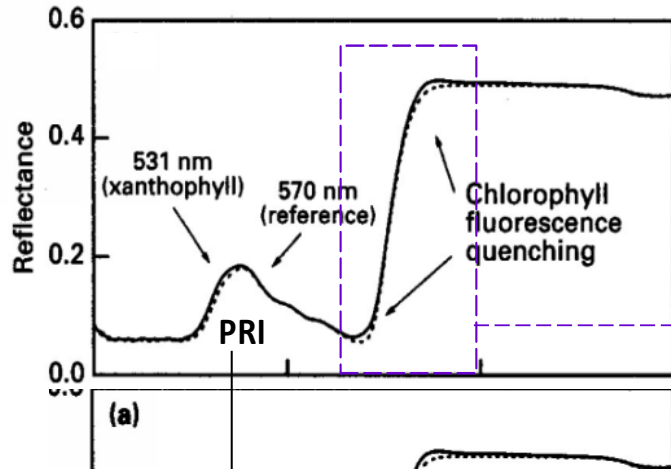

b) QEPro spectral range

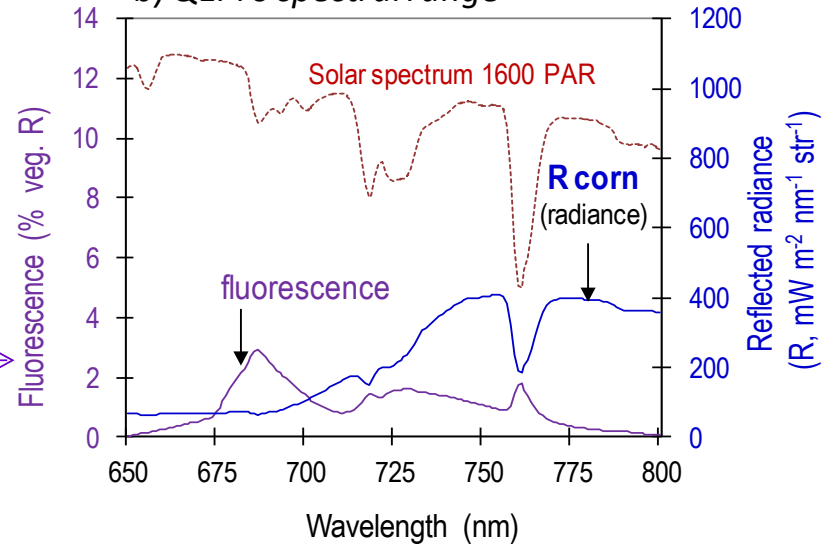

c) Photochemical Reflectance Index (PRI)

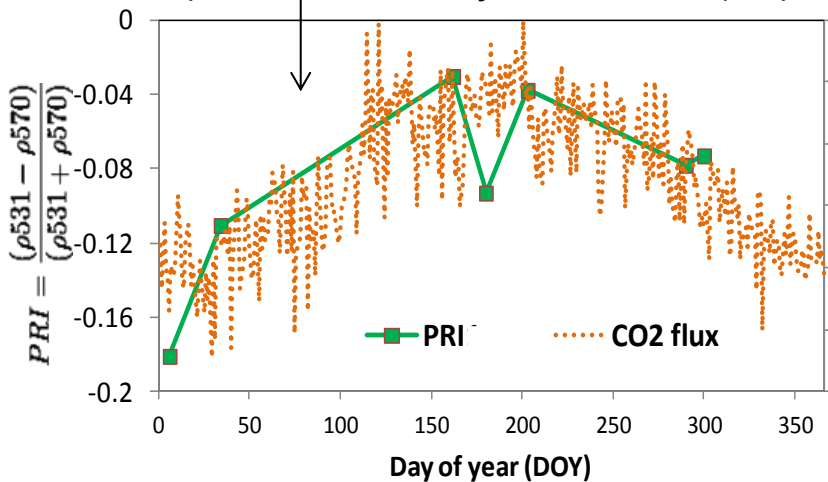

To characterize ecosystem biochemical and physiological parameters we will use: reflectance (a) and solar-induced fluorescence (b).

We will use high spectral resolution discrete measurements (Yr1) and imaging spectroscopy (Yr2).

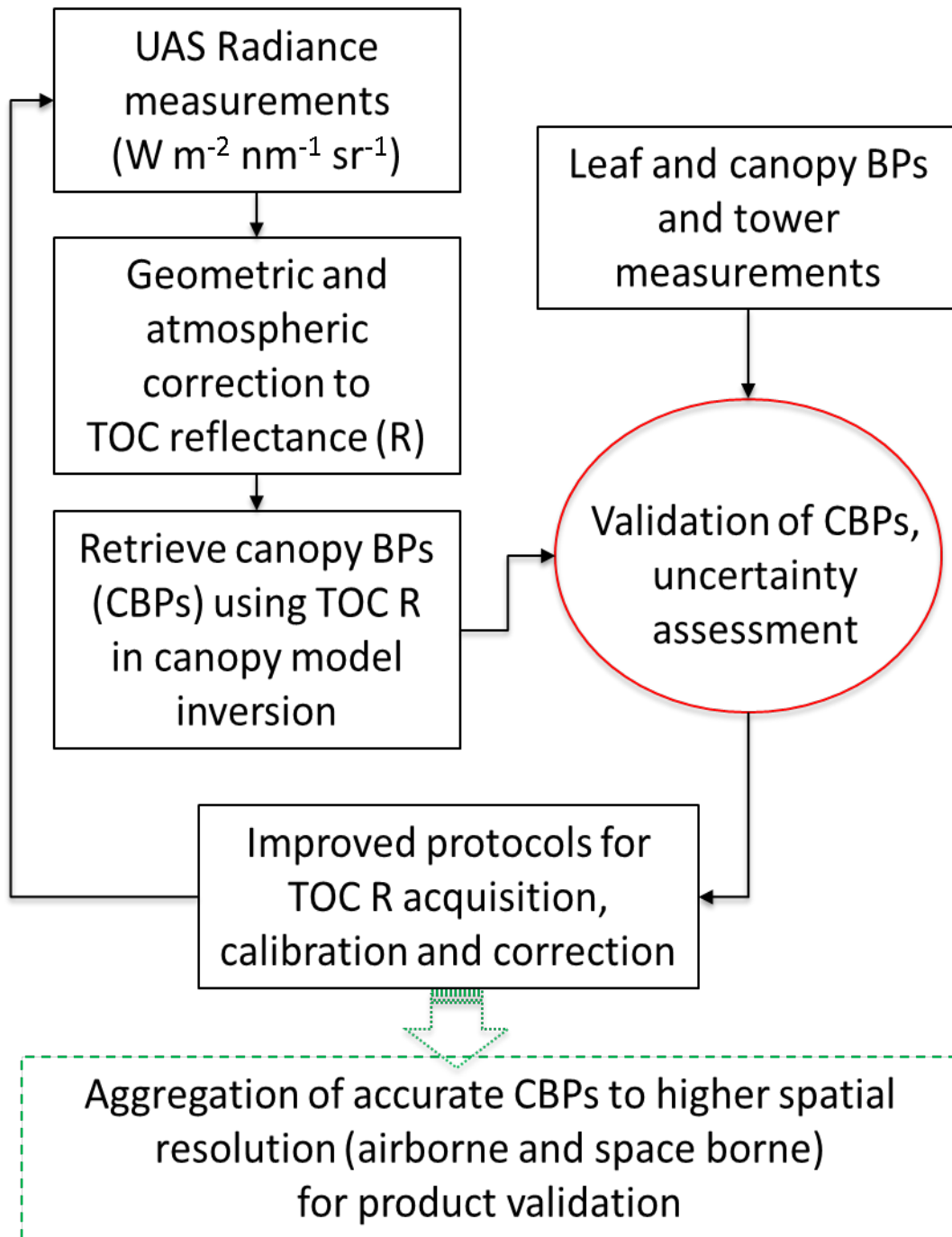

Workflow for retrieval of Biophysical Parameters (BPs), validation and improvement (after Vuolo et al. 2012).

TOC – Top of canopy
 CBP - Canopy Biophysical Properties
 R - Reflectance

UASs SensorWeb capabilities

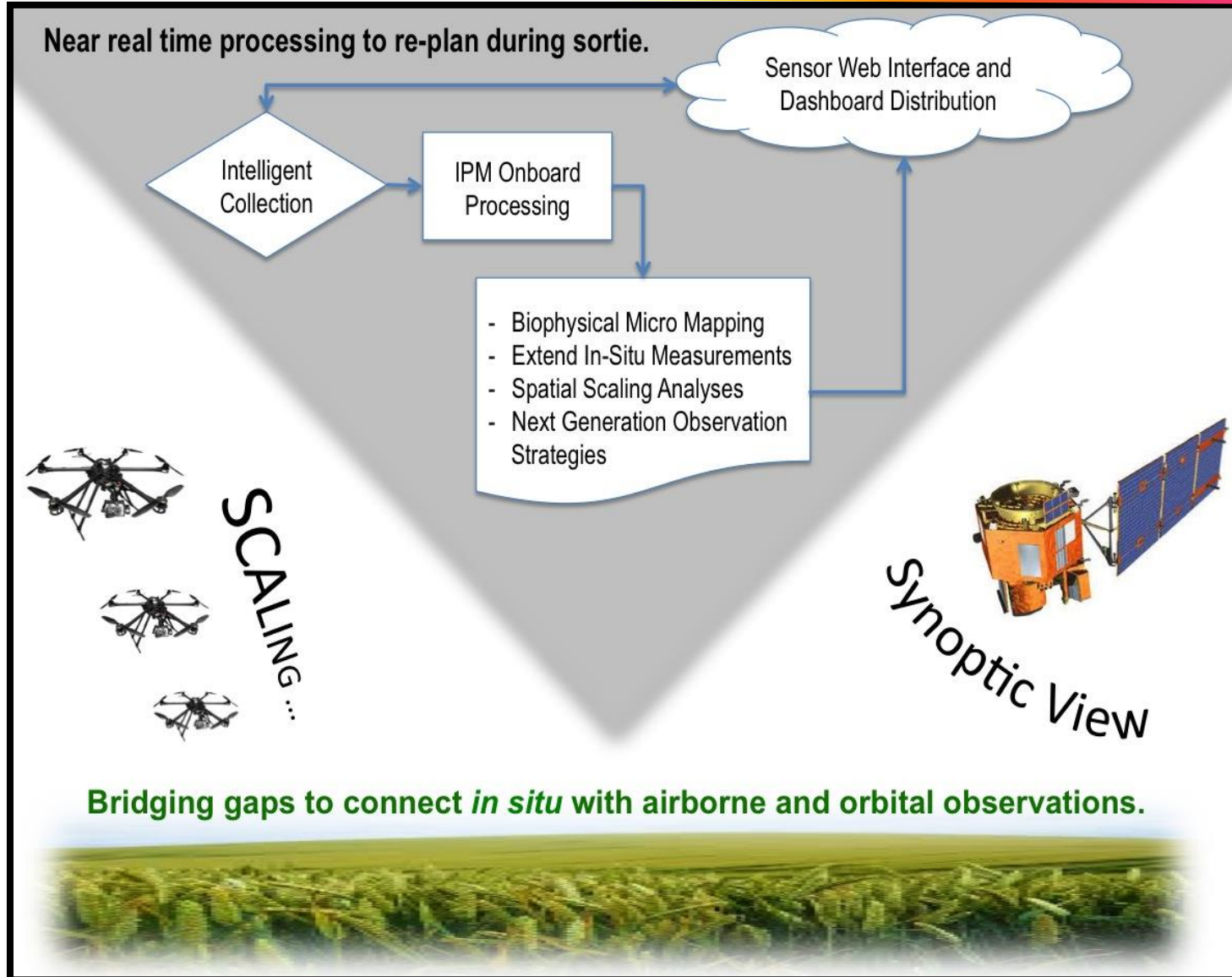

SensorWeb and IPM Definition

- SensorWeb - a set of sensors (land, marine, air, space) and processing which interoperate in a (semi) automated collaborative manner for scientific investigation, disaster management, resource management, and environmental intelligence”.
 - More information at: <http://sensorweb.nasa.gov>
- Intelligent Payload Module (IPM) - Adapter for SensorWeb for high speed sensor data which is a combination of flight hardware and flight software that provides data subsets and/or higher level data products in near real time or realtime

Original Driving Operations Concept for IPM

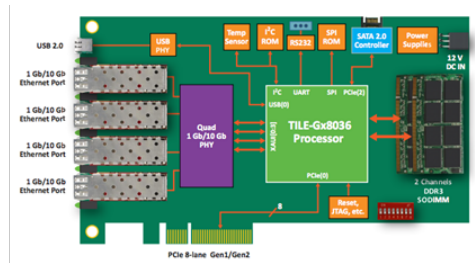

Onboard multicore processor or single Linux Processor



FPGA Onboard Accelerator

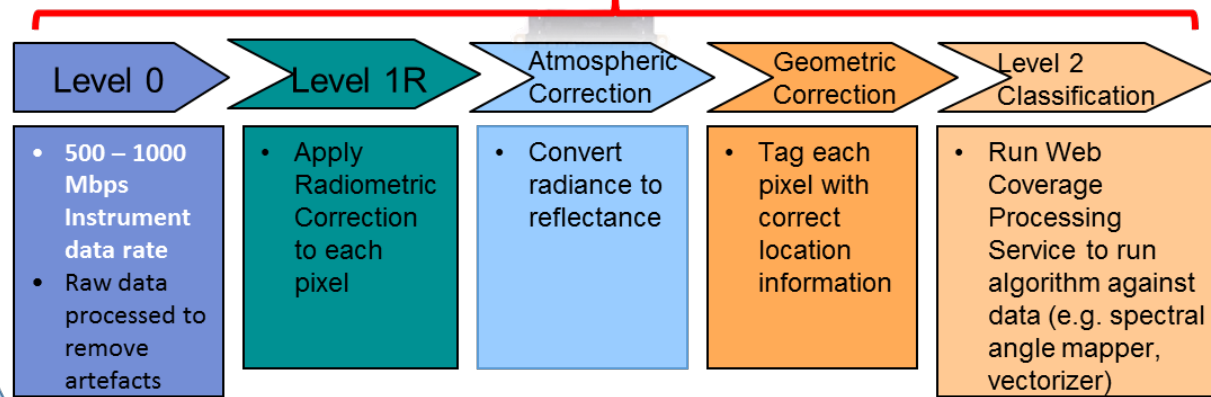

Level 0

- 500 – 1000 Mbps Instrument data rate
- Raw data processed to remove artefacts

Level 1R

- Apply Radiometric Correction to each pixel

Atmospheric Correction

- Convert radiance to reflectance

Geometric Correction

- Tag each pixel with correct location information

Level 2 Classification

- Run Web Coverage Processing Service to run algorithm against data (e.g. spectral angle mapper, vectorizer)

Downlink RT Algal Bloom Maps to Users on Bay 10 Mbps

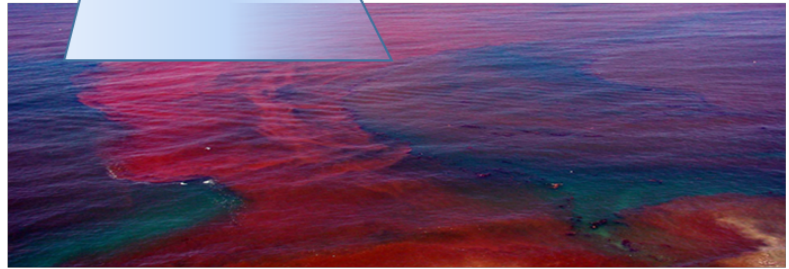

Original Intelligent Payload Module Box v1 – Hardware Developed Under AIST-11 “A High Performance Onboard Multicore Intelligent Payload Module for Orbital and Suborbital Remote Sensing Missions

- 14.5 x 14.5 x 7 inches
- Wide-Input-Range DC voltage (6V-30V)
- Made of strong durable aluminum alloy
- Dual mounting brackets
- Flush design
- Removable side panels
- Mounting racks are electrically isolated from the box
- Electronic components
 - Tiler development board (TILEPro64)
 - Xilinx Zynq development board (MicroZed)
 - Single board computer (Dreamplug)
 - 600GB SSD
 - Gigabit Ethernet switch
 - Transceiver radio
 - Power board

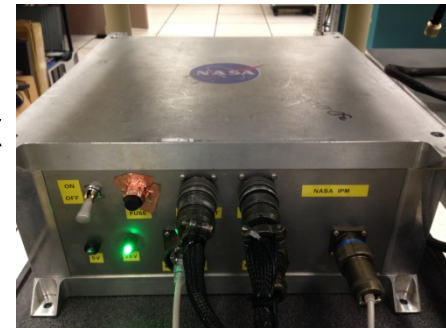
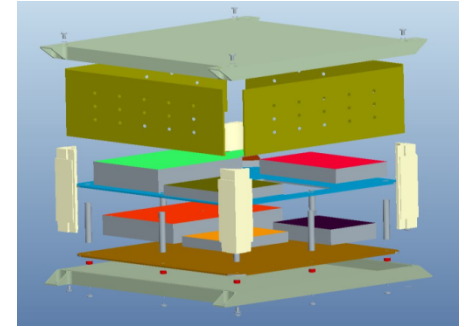

Original Integration and Flights of IPM and Hyperspectral Instrument Box on Bussmann Helicopter



- 7/16/2014 – Manassas Airport Area – Test flight
 - Had EMI problems, interfering with Pilot Aviation Bands 118 MHz to 137MHz
 - Had imaging problems due to software bug
- 7/23/2014 – Manassas Airport Area – Test flight
 - Had EMI problems – Tiler CPU is leaking 125MHz signal
- 9/24/2014 – Manassas Airport Area – Test flight
 - Had imaging problems due to the shutter
- 1/20/2015 – Manassas Airport Area
 - Successful Flight
- 4/13/2015 – Patuxent Environmental & Aquatic Research Laboratory (PEARL) Center Flight from Manassas (Leaf Off)
 - Successful Flight



Manassas Regional Airport

Original Hyperspectral Data Processing Software on IPM

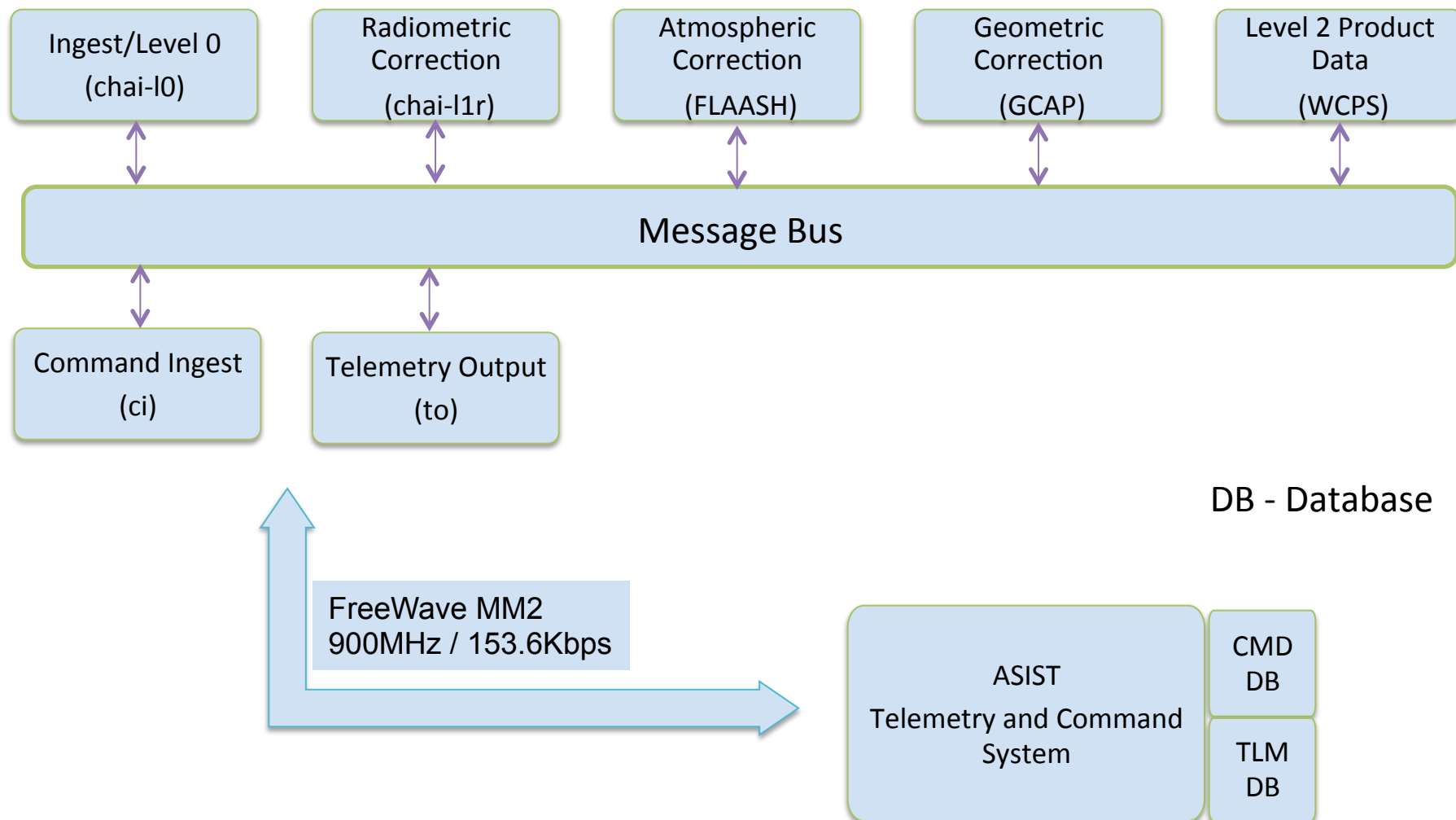

IPM Test Flight Bussmann Helicopter

April 13th 2015 / St. Leonard, MD at the

Patuxent Environmental and Aquatic Research Lab (PEARL) – Morgan State

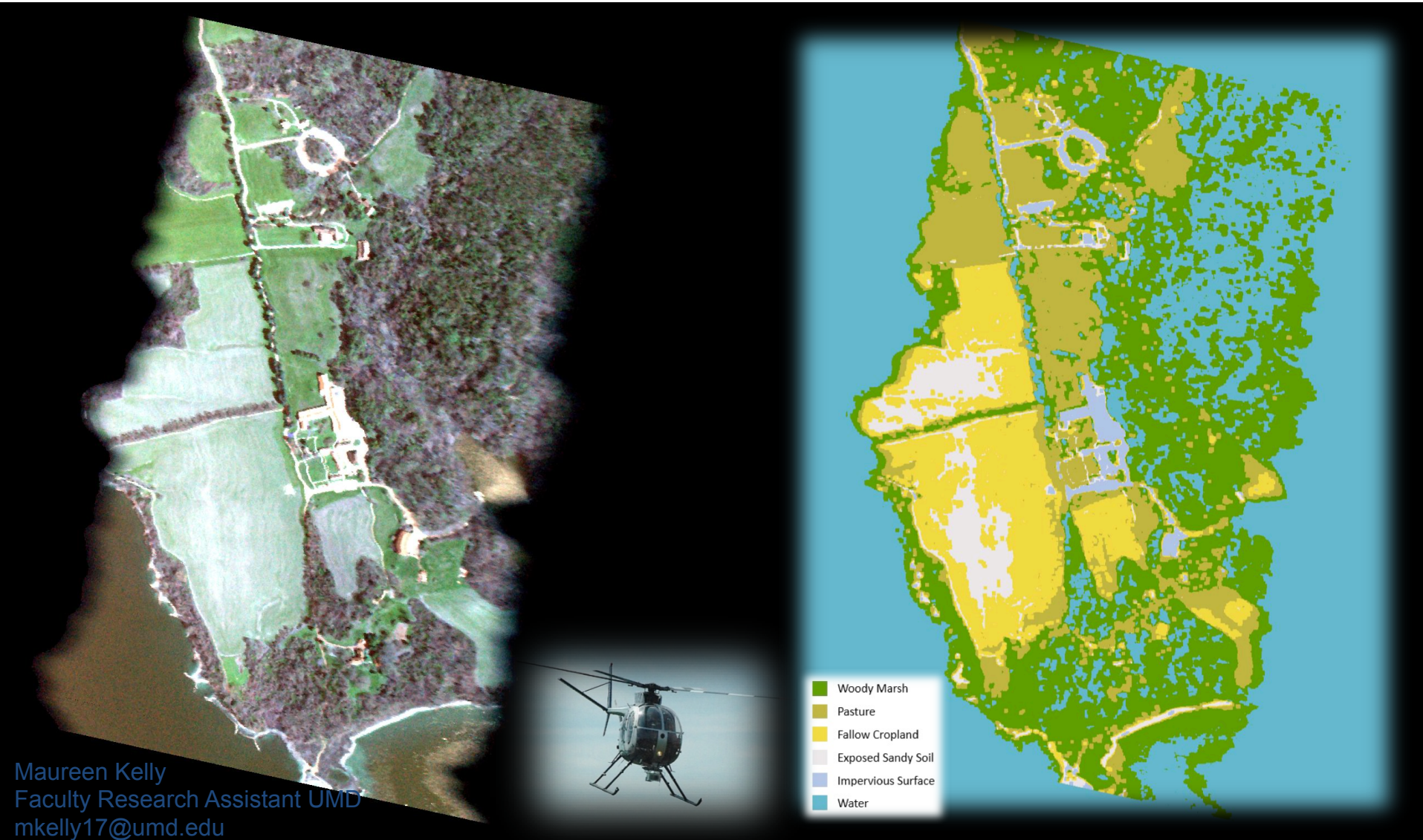

IPM Test Flight Bussmann Helicopter April 13th 2015 / St. Leonard, MD at the

Patuxent Environmental and Aquatic Research Lab (PEARL) – Morgan State
Univ

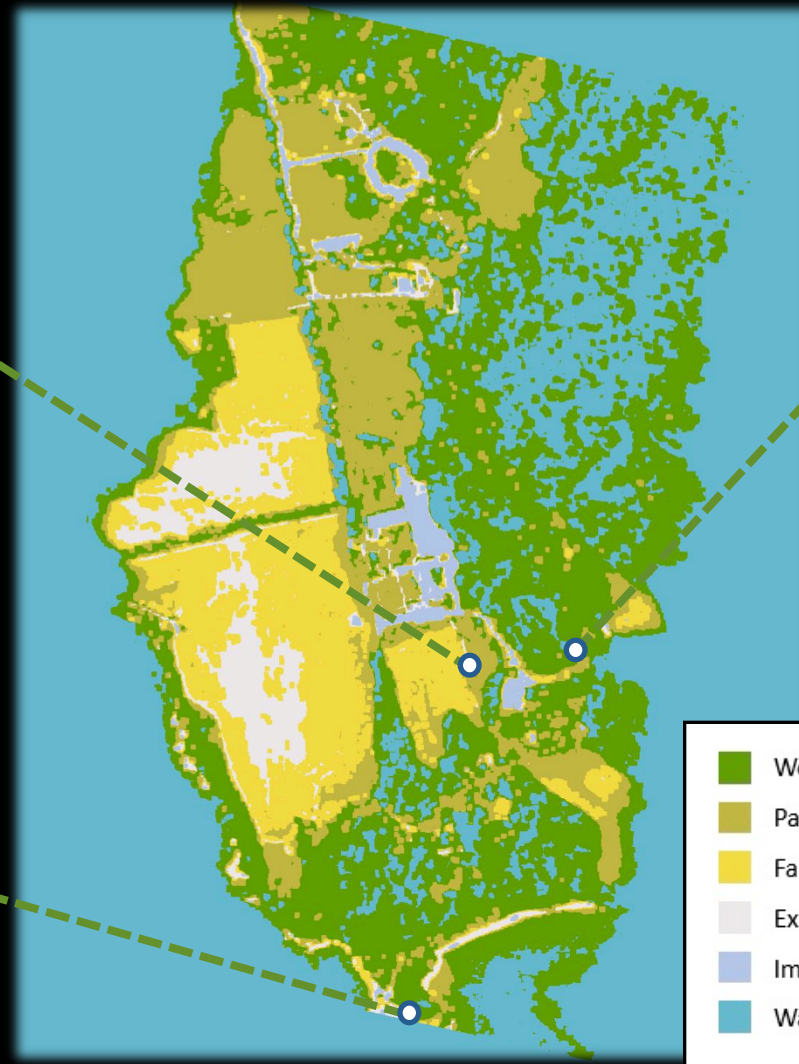

- Woody Marsh
- Pasture
- Fallow Cropland
- Exposed Sandy Soil
- Impervious Surface
- Water

Maureen Kelly
Faculty Research Assistant UMD
mkelly17@umd.edu

Evolving Set of Platforms Targeted for IPM

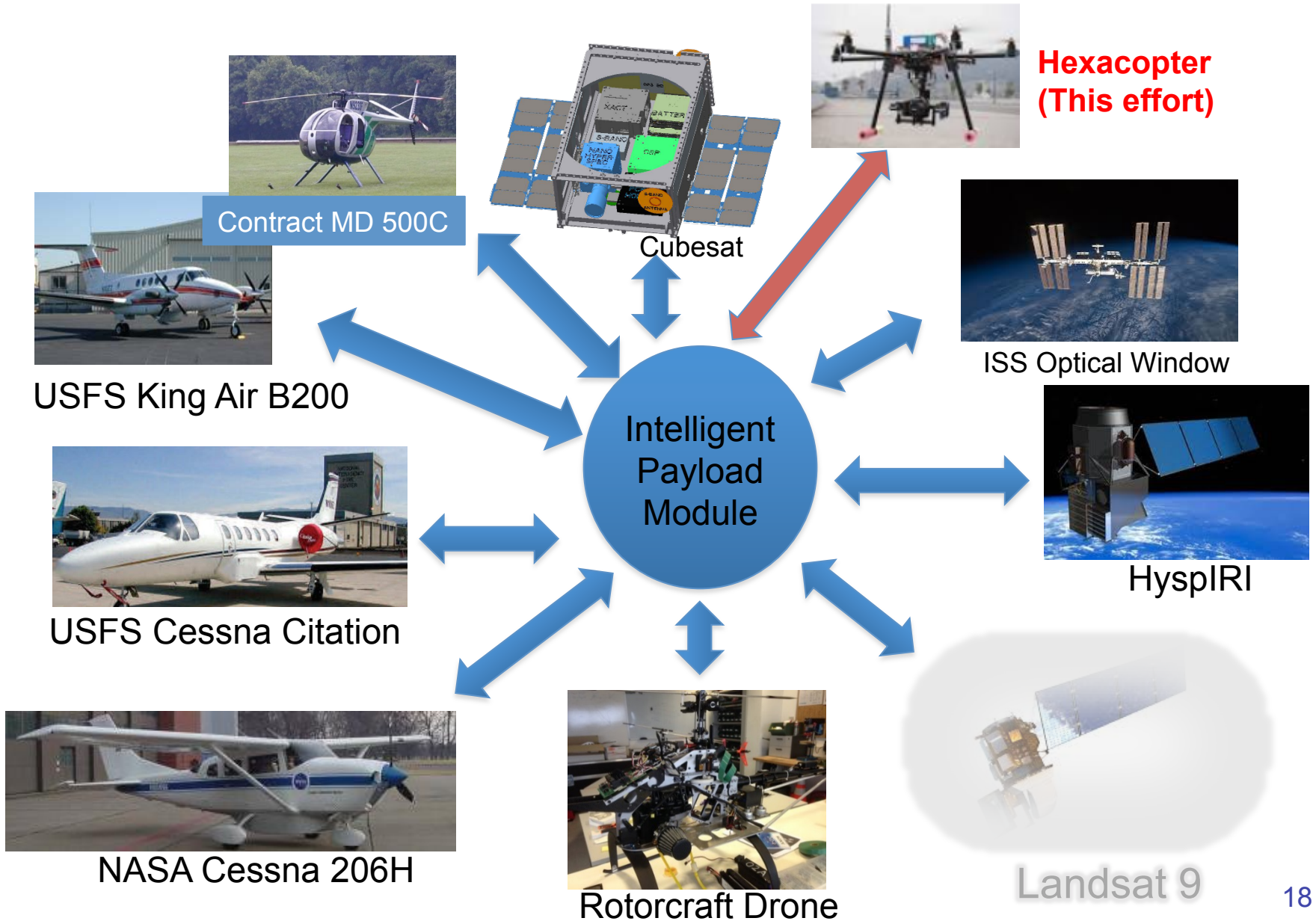

IPM as an Evolving Platform Integrating HW and SW Components

HW Components

SpaceCube 1.0



2005

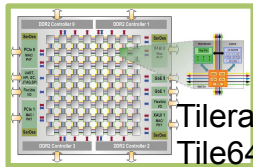

Tilera
Tile64
TileGX

Zynq
ZC7020

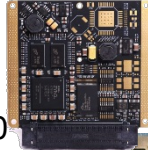

2010



SpaceCube 2.0
PowerPC
Virtex5



IPM 1.0

2015

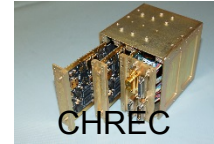

CHREC
Space Processor
Cubesat
ARM/Zynq FPGA

2020

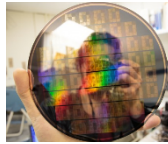

Processors with nano-material

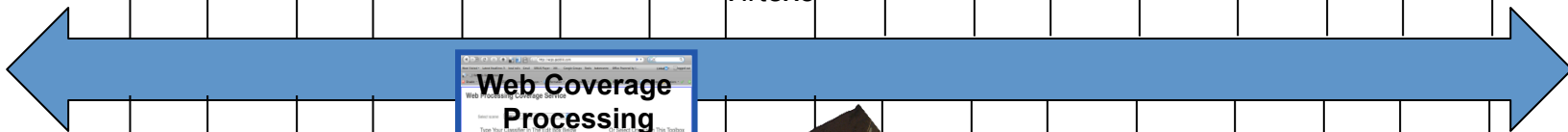

SW Components

SensorWeb Enablement (SWE)
OGC Standards

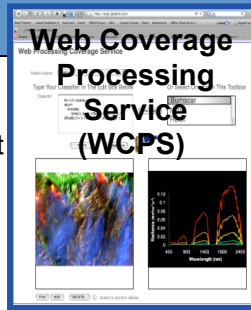

Geocorrection For Airborne Platform (GCAP)

Atmospheric Correction

AESOP automated parallelization

Automated High Level Synthesis of FPGA circuits and Linux API

IPM Weight	5-20 lbs	<1 lb
IPM Power	20 – 80 watts	<10 watts
IPM Clock	100 Mhz – 800 Mhz	<2-3 watts
Data Throughput	50 kbps – 1 Gbps	>300 Mhz
		>10 Gbps

IPM for This Effort

- Shrink IPM: Using MicroZed Z-7020 in smaller box
 - Based on Zynq chip, 2 ARM processors, 53K look-Up tables and 100K gates

Device Name	Z-7010	Z-7015	Z-7020	Z-7030	Z-7035	Z-7045	Z-7050
Part Number	XC7Z010	XC7Z015	XC7Z020	XC7Z030	XC7Z035	XC7Z045	XC7Z050
Xilinx 7 Series Programmable Logic Equivalent	Artix®-7 FPGA	Artix-7 FPGA	Artix-7 FPGA	Kintex®-7 FPGA	Kintex-7 FPGA	Kintex-7 FPGA	Kintex-7 FPGA
Programmable Logic Cells (Approximate ASIC Gates) ⁽³⁾	28K Logic Cells (~430K)	74K Logic Cells (~1.1M)	85K Logic Cells (~1.3M)	125K Logic Cells (~1.9M)	275K Logic Cells (~4.1M)	350K Logic Cells (~5.2M)	440K Logic Cells (~5.8M)
Look-Up Tables (LUTs)	17,600	46,200	53,200	78,600	171,900	218,600	237,600
Flip-Flops	35,200	92,400	106,400	157,200	343,800	437,200	514,800
Extensible Block RAM (# 36 Kb Blocks)	240 KB (60)	380 KB (95)	560 KB (140)	1,060 KB (265)	2,000 KB (500)	2,180 KB (545)	3,020 KB (755)
Programmable DSP Slices (18x25 MACCs)	80	160	220	400	900	900	2,020

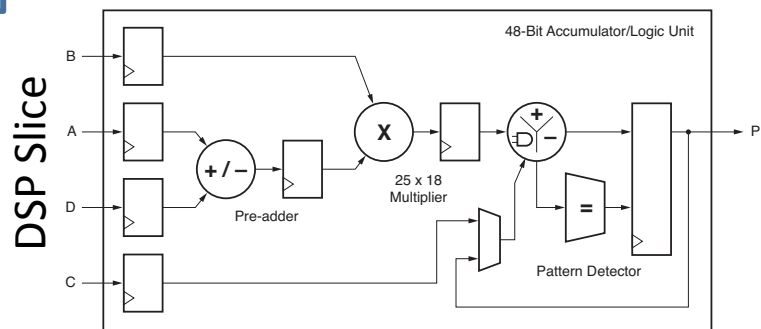
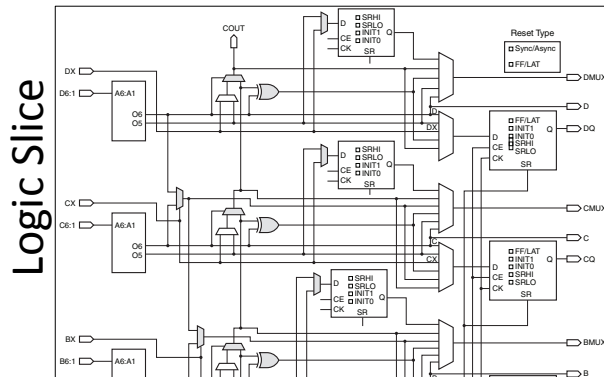
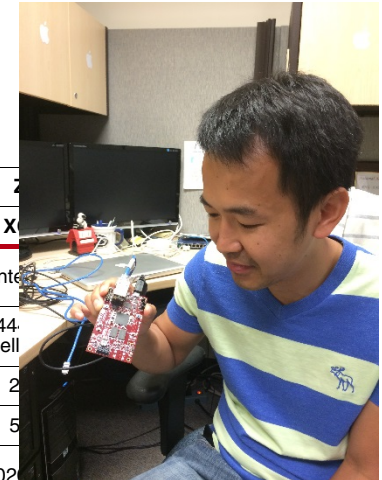

UG479_c1_21_032111

- FPGA fabrics are mostly programmable logic slices: look-up-tables (LUTs) and registers together in a larger block
- Theoretically, logic slices could implement anything, but “hard” ASIC logic is often faster and more efficient

IPM for This Effort

- Image aided navigation
 - ✓ Onboard processing of data processing chain of hyperspectral data from *Piccolo Doppio* spectrometer and Headwall Nano-hyperspec or equivalent imaging spectrometer
 - ✓ Data subsetting
 - ✓ Real time campaign/way point adjustments based on measurements and objectives (autonomous scheduling, goal oriented abstraction)
 - Possible use of Autonomous Sciencecraft Experiment (presently used on EO-1)
- Data product distribution to dashboard and possible use of social media (GeoSocial API, onboard publisher, ground consumer)

Z-7020 – Zynq (ARM/FPGA Processor) Proxy for COTS+RH+FTC CHREC Space Processor (CSP)

COTS

- Zynq-7020 hybrid SoC
 - Dual ARM A9/NEON cores
 - Artix-7 FPGA fabric + hard IP
- DDR3 memory

RadHard

- NAND flash
- Power circuit
- Reset circuit
- Watchdog unit

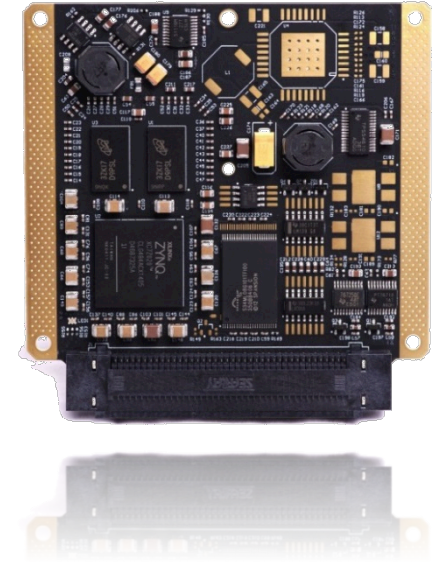

FTC = Fault-Tolerant Computing

- Variety of mechanisms
 - External watchdog unit to monitor Zynq health and reset as needed
 - RSA-authenticated bootstrap (primary, secondary) on NAND flash
 - ECC memory controller for DDR3 within Zynq
 - ADDAM middleware with message, health, and job services
 - FPGA configuration scrubber with multiple modes
 - Internal watchdogs within Zynq to monitor behavior
 - Optional hardware, information, network, software, and time redundancy

CHREC Space Processor on ISS and Cubesat

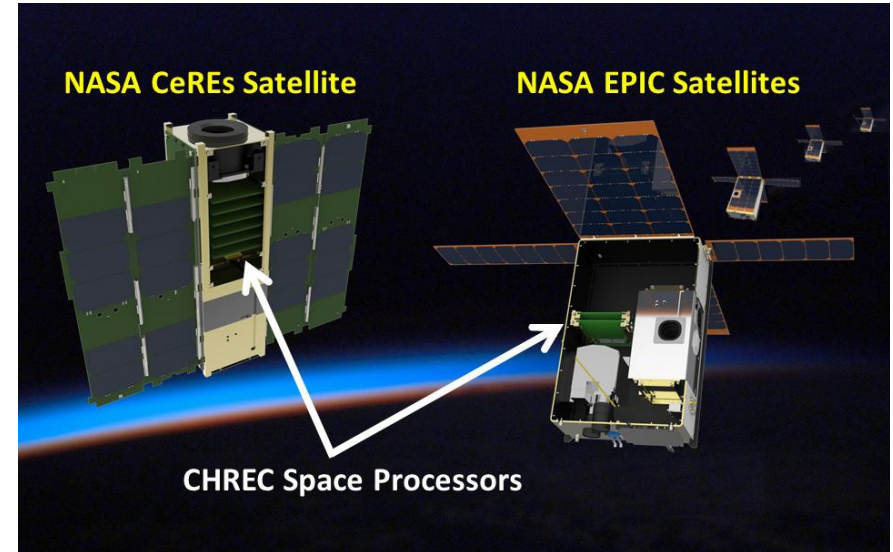
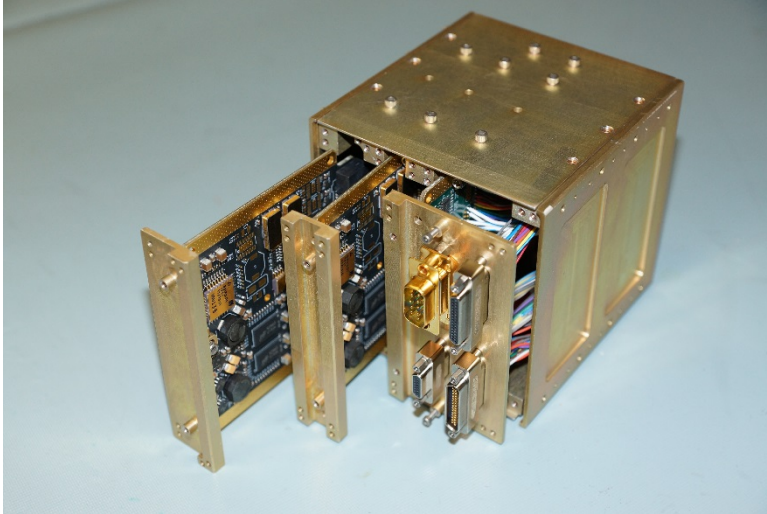

- CSP/SpaceCube Tech Demo ISIM (Space Station)
 - ✓ 2 CSP's, SpaceCube 1.0, 1.5, 2.0
 - ✓ Delivered to DoD early FY15 and launched early FY16
 - ✓ Gary Crum/587
- Compact Radiation BElt Explorer (CeREs) is part of NASA's Low-Cost Access to Space program
 - ✓ 3U Cubesat
 - ✓ 1 CSP
 - ✓ Delivery to GSFC early 2015, Launch 2016

Publisher/Consumer/GeoSocial API Architecture

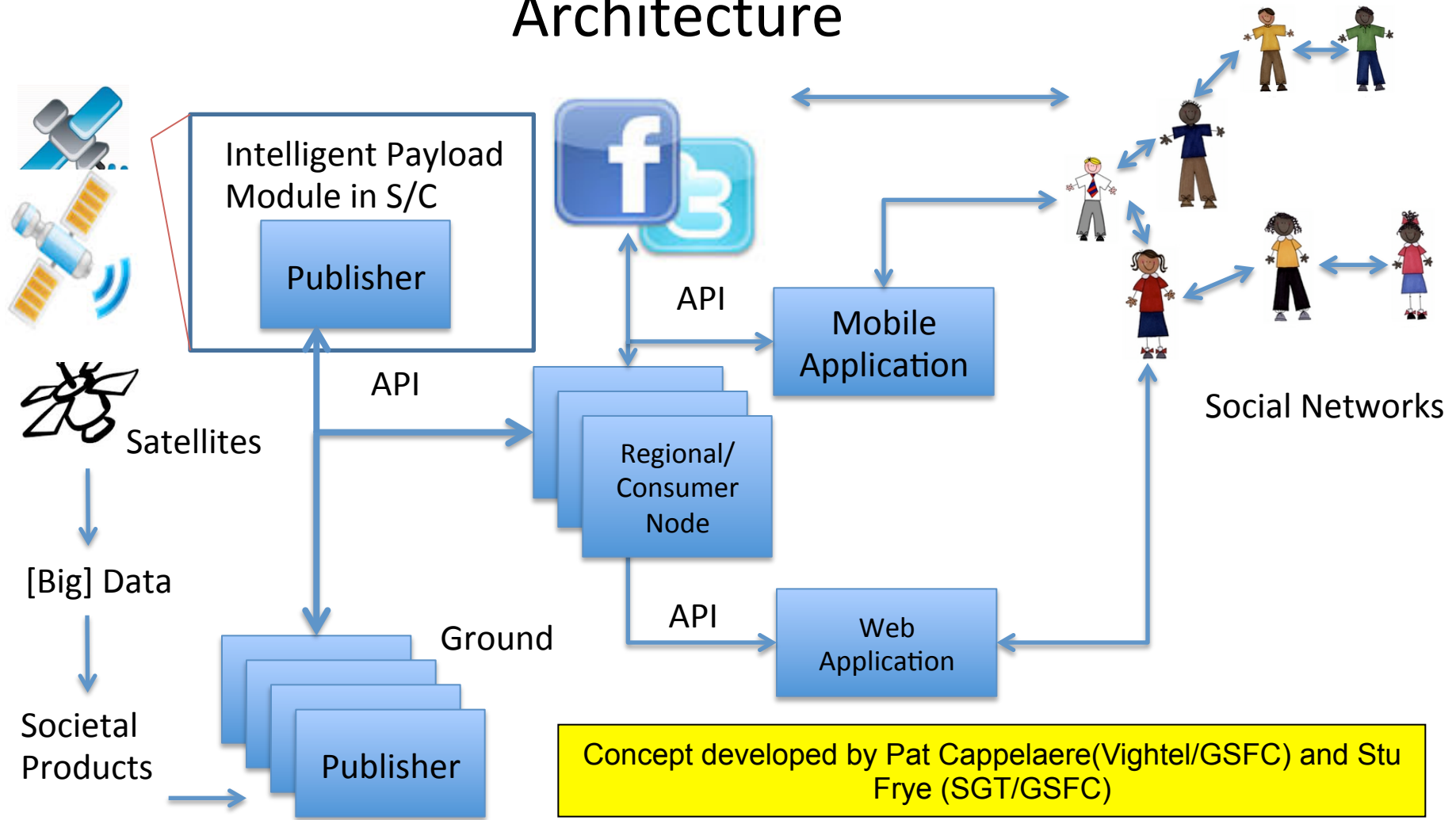

A methodology to rapidly discover, obtain and distribute satellite data products via social network and open source software

Basic SensorWeb Architecture

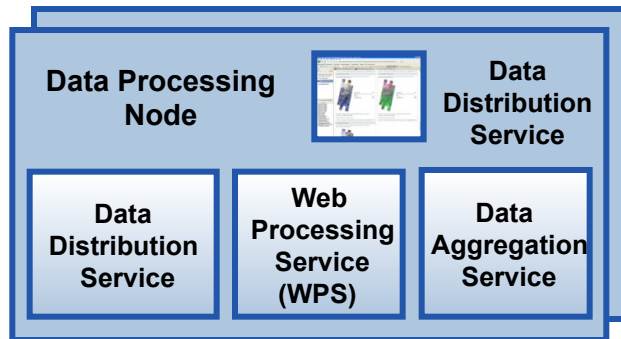
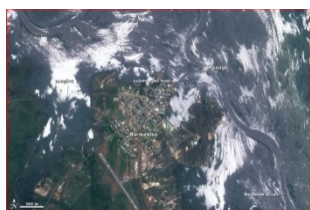

Sensor Data Products

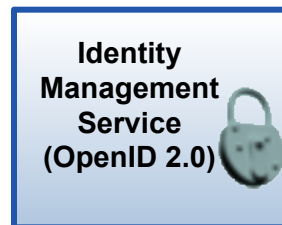
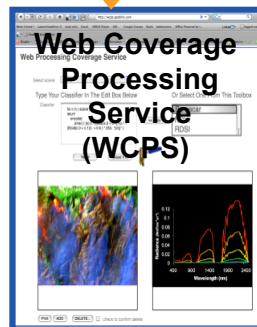
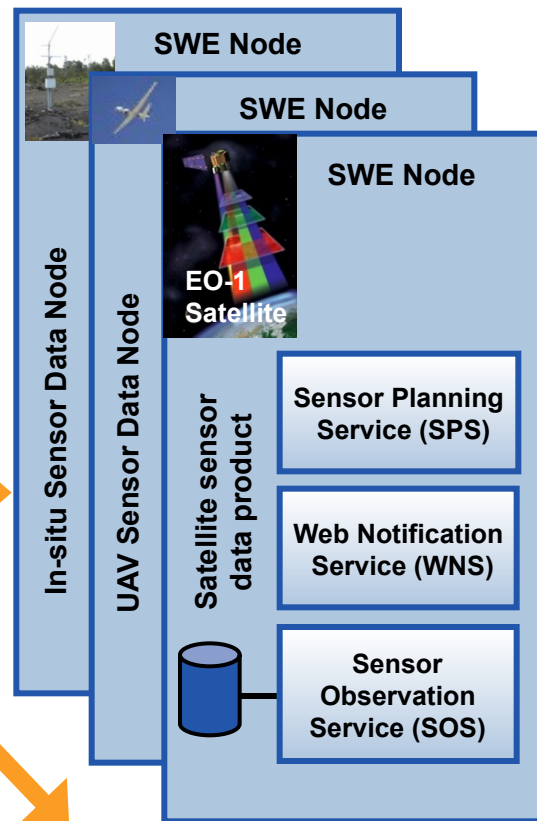
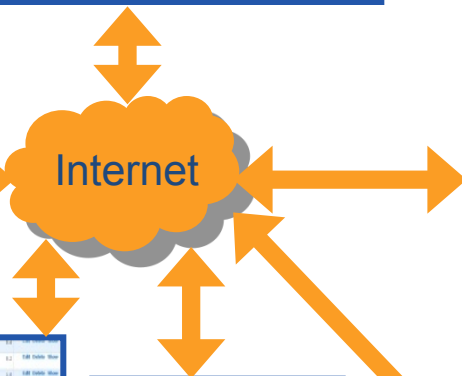

SensorWeb Enablement (SWE)
OGC Standards

GSFC SensorWeb Components (Ground)

SensorWeb Toolkit Subsystem	Type	NTR	How long in operation	TRL	Developed Under	Note
SensorWeb Reference Architecture	Arch	GSC-5025286	7 years +	9	AIST-05	Active on EO-1
Campaign Manager (GeoBPMS)	WfCS	GSC-16267-1	5 years	9	AIST-05	Active on EO-1
Campaign Manager Client	WfCS	GSC-5027514	2 years	7	AIST-05	Not used
Identity Management Services	Security	GSC-16268-1	5 years	9	AIST-05	Active on EO-1
EO-1 SPS 0.3 (GSFC)	SPS	GSC-16271-1	5 years	9	AIST-05	Active on EO-1
EO-1 SOS	SOS	GSC-16272-1	5 years	7	AIST-05	Active on EO-1
OGC Publish/Subscribe Basic	WNS	GSC-16270-1	5 years	9	AIST-05	Active on EO-1
WCPS	WCPS	GSC – 16273-1	3 years	9	AIST-08	Active on EO-1
Weka to WCPS Translator	WCPS	GSC-16274-1	3 years	7	AIST-08	Not used
Flood Dashboard	DADM	GSC-16275-1	3 years	9	EO-1	Active Namibia, Central America, others
GeoSocial API	WfCS	GSC-17162-1	0 years	6	AIST-QRS11	Namibia, Central America, others
Flood Vectorization Topojson	WCPS	GSC-17169-1	0 years	6	TBS	Demo mode
Geo-Registration of Multi-Source Image Data	WCPS	GSC-16862-1	0 Years	6	TBS	Demo mode

Arch- Architecture
WfCS – Workflow Chaining Service
SPS – Sensor Planning Service

WCPS – Web Coverage Processing Service
WNS – Web Notification Service
DADM – Data Aggregator and Display Mashup

JPL SensorWeb Components (Ground)

SensorWeb Toolkit Subsystem	Type	NTR	How long in operation	TRL	Developed Under	Note
Intelligent Payload Module	WfCS	JPL-45445	6 years	9		Active on EO-1
	WfCS	JPL-48148	6 years +	9		Active on EO-1
MODIS-based Flood Detection, Tracking and Response	WfCS	JPL-48149	4 years	9		Active
Change based satellite monitoring using broad coverage targetable sensors	WfCS*	JPL-48147	7 years	9		Active on EO-1
EO-1 SPS 2.0	SPS	JPL-48142	5 years +	9		Active on EO-1
WPS Software Framework	WPS	JPL-45998	6 years	9		Active on EO-1
Autonomous Hyperspectral Data Processing/Dissemination	WfCS*	JPL-48123	7 years	9		Active on EO-1

Arch- Architecture

WfCS – Workflow Chaining Service

SPS – Sensor Planning Service

WNS – Web Notification Service

WCPS – Web Coverage Processing Service

DADM – Data Aggregator and Display Mashup

* - Noncompliant with OGC Standards

IPM SensorWeb Internal SW Components (Onboard)

SensorWeb Toolkit Subsystem	Type	NTR	How long in operation	TRL	Developed Under	Note
Intelligent Payload Module	WfCS	GSC-16867-1	Assorted		AIST-11	
- cFE command in integrated into IPM	-Til		6 months	7		Active Bus helo
- cFE telemetry out integrated into IPM	-Til		6 months	7		Active Bus helo
- cFE CFDP integrated into IPM	-Til		6 months	7		Active Bus helo
- WCPS integrated into IPM	-Til		6 months	7		Active Bus help
- GCAP single processor	-Til		6 months	6		Active Bus helo
- GCAP parallel processed on multicore	- Til		6 months	6		Active on testbed
- FLAASH Atmospheric Corr, one proc	- Til		6 months	5		Active on testbed
- FLAASH Atmospheric Corr, parallel	- Til		6 months	4		Active on testbed
- Spectral Angle Mapper	- Til		6 months	6		Active Bus helo
- Instrument data ingest	- FPGA			3		Helo/cubesat
- FLAASH AC	- FPGA			3		Helo/cubesat
- GCAP	- FPGA			3		Helo/cubesat

Arch- Architecture
WfCS – Workflow Chaining Service
SPS – Sensor Planning Service
WNS – Web Notification Service
WCPS – Web Coverage Processing Service

DADM – Data Aggregator and Display Mashup
• - Noncompliant with OGC Standards
Til – on Tileria multicore
GCAP – Geocorrection for Airborne Platforms

KEY MILESTONES and TECHNICAL APPROACH

- Integrate and test Ocean Optics spectrometer and *Piccolo Doppio* upwelling/downwelling foreoptic onto UAS, and establish calibration protocols
- Parameter retrieval and validation of measurements at well-characterized sites
- Develop Rapid Data Assimilation and delivery system, based on SensorWeb Intelligent Payload Module high speed onboard processing developed under AIST-11 and other cloud based data processing chain functionality (<http://sensorweb.nasa.gov>);
- Develop data gathering campaign strategy to optimize data yield;
- Leverage EcoSIS online spectral library
- Integration of Headwall imaging spectrometer, inter-calibration to *Piccolo Doppio*
- Validate real-time computing capacity
- Parameter retrieval maps and validation against field data
- Data Production Pipeline Demo

ANTICIPATED OUTCOME

This research effort will enable the acquisition of science-grade spectral measurements from UASs.

The UAS collections at 10-150m altitude would bridge the gap between ground/proximal and airborne measurements, typically acquired at 500m and higher, allowing better linkage of comparable measurements across the full range of scales from ground to satellites.

Backup

Original Hyperspectral Instrument used

- Chai v640 Instrument Box

- 12 x 10 x 7 inches
- Wide-Input-Range DC voltage (6V-30V)
- Made of strong durable aluminum alloy
- Dual mounting brackets
- Flush design
- Removable side panels
- Mounting racks are electrically isolated from the box
- Electronic components
 - CHAI V640
 - Frame Grabber
 - Systron SDN500
 - UNIBLITZ Shutter Driver
 - USB Hub
 - Phidgets Temperature Sensor

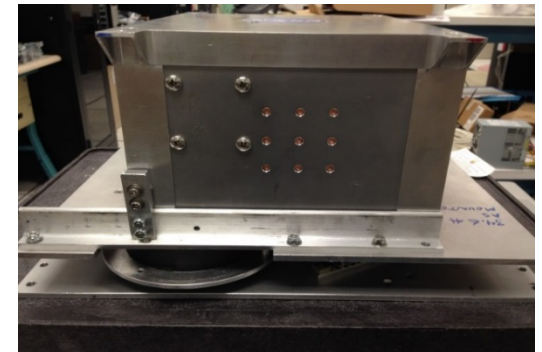
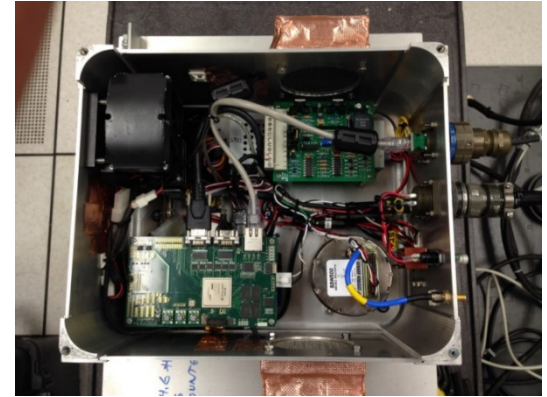

Bussmann Helicopter Flights

- 7/16/2014 – Manassas Airport Area – Test flight
 - Had EMI problems, interfering with Pilot Aviation Bands 118 MHz to 137MHz
 - Had imaging problems due to software bug
- 7/23/2014 – Manassas Airport Area – Test flight
 - Had EMI problems – Tiler CPU is leaking 125MHz signal
- 9/24/2014 – Manassas Airport Area – Test flight
 - Had imaging problems due to the shutter
- 1/20/2015 – Manassas Airport Area
 - Successful Flight
- 4/13/2015 – Patuxent Environmental & Aquatic Research Laboratory (PEARL) Center Flight from Manassas (Leaf Off)
 - Successful Flight



CS65 65mm Uni-stable Shutter



Next Generation UAV Spectral Systems for Environmental Modeling

PI: Petya Campbell, UMBC

Objective

- Develop capability to depict diurnal and seasonal cycles in vegetation function:
 - accurate measurements of vegetation reflectance at high spectral resolution
 - high temporal frequencies and stability
 - Spatial variability with high resolution
 - Optimize data acquisition and workflow
- Demonstrate the capability to produce science-quality spectral data from UAVs
 - suitable for scaling ground measurements
 - comparison to from-orbit data products
- Small UAV hyperspectral sensor-web, filling the gap between ground and satellite measurements

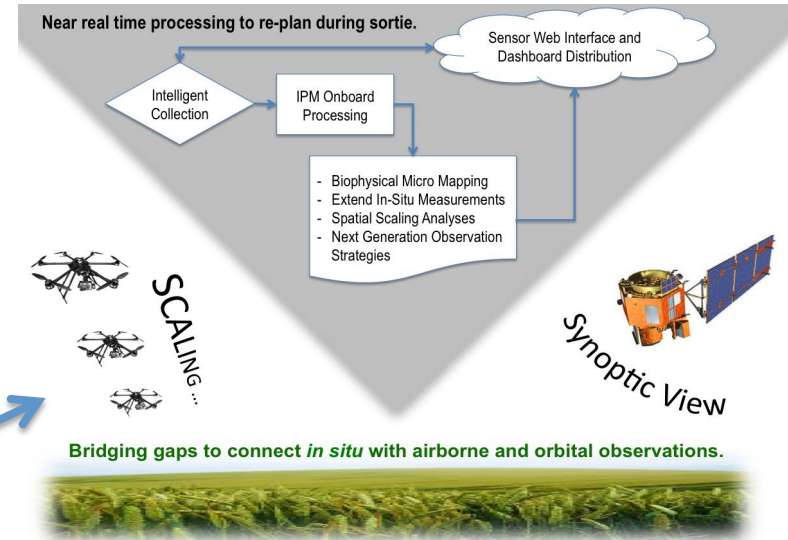

Approach:

- Integrate and test Ocean Optics spectrometer and Piccolo upwelling/downwelling foreoptic onto UAV.
 - Validate measurements at well-characterized sites.
- Develop Rapid Data Assimilation and delivery system.
- Develop data gathering campaign strategy to optimize data yield.
 - Leverage EcoSIS online spectral library.

Cols: P. Townsend (lead), C. Kingdon and F. Navarro, UW; D. Mandl (lead) and V. Ly, GSFC; V. Ambrosia, CSUMB; P. Cappelaere, Vightel; L. Corp, Sigma Space; J. Nagol and R. Sohlberg, UMD; L. Ong, SSAI.

Key Milestones

- **Start Project** **06/15**
- Spectrometer integration 07/15
- Calibration protocol, intercalibration (initial) 09/15
- Preliminary parameter retrievals and validation 11/15
- Integration of Headwall imaging spectrometer 02/16
- Validate computing capacity for real-time 12/16
- Parameter retrieval/validation against field data 12/16
- **Data Production Pipeline Demo (TRL 5)** **05/17**

TRL_{in} = 3

IPM Test Flight Bussmann Helicopter

April 13th 2015 / St. Leonard, MD

20150413_A1

20150413_A2

20150413_B1

20150413_B2

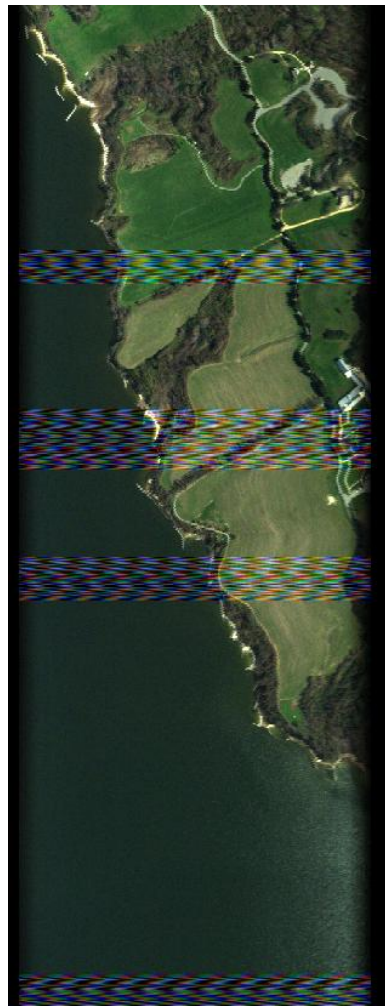
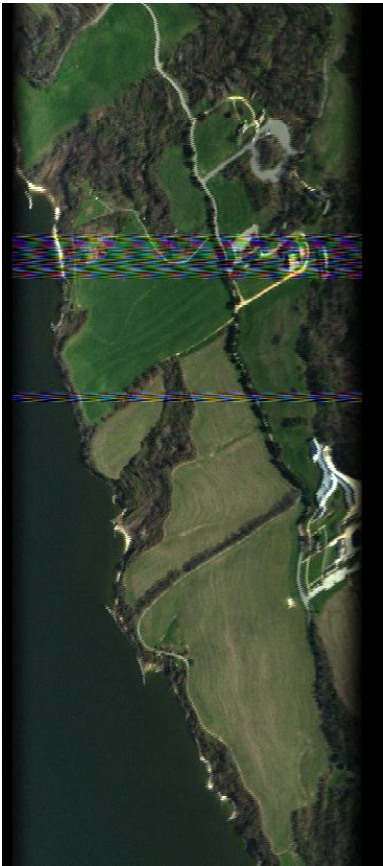

IPM Test Flight Bussmann Helicopter

April 13th 2015 / St. Leonard, MD

20150413_C1

20150413_C2

20150413_D1

20150413_D2

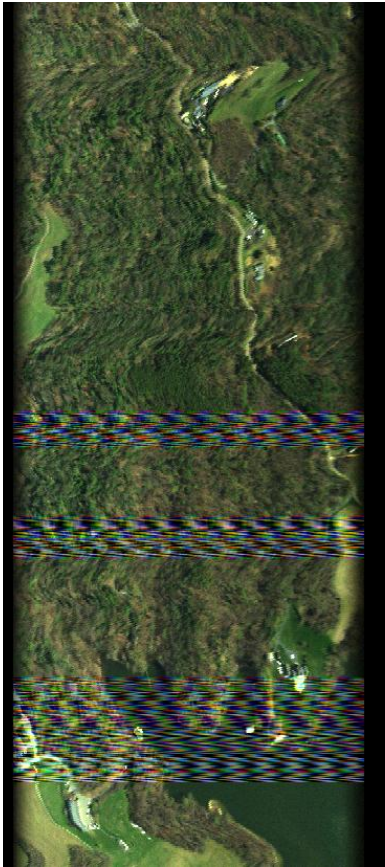

IPM Test Flight Bussmann Helicopter April 13th 2015 / St. Leonard, MD

Search

ex: 15213

Get Directions History

Places

- My Places
 - Sightseeing Tour
 - Make sure 3D Buildings layer is checked
- Temporary Places
 - Instrument chai 20150413_A1
 - Instrument chai scene:20150413_A1
 - Instrument chai 20150413_B2
 - Instrument chai scene:20150413_B2
 - Instrument chai 20150413_C2
 - Instrument chai scene:20150413_C2
 - Instrument chai 20150413_D2
 - Instrument chai scene:20150413_D2

Layers

Earth Gallery >>

- Primary Database
 - Borders and Labels
 - Places
 - Photos
 - Roads
 - 3D Buildings
 - Ocean
 - Weather
 - Gallery
 - Global Awareness
 - More

© 2015 Google

Google Earth

Tour Guide 1993

38°23'36.39" N 76°30'40.10" W elev 1 ft eye alt 4826 ft

IPM Test Flight Cessna 206

May 5th 2015 / St. Leonard, MD

20150505_A1

20150505_B2

20150505_C1

20150505_D1



IPM Test Flight Cessna 206

May 27th 2015 / St. Leonard, MD

20150527_A2_2

20150527_B2_2

20150527_C2_2

20150527_D2_2



IPM Test Flight Cessna 206

May 27th 2015 / St. Leonard, MD

Preliminary Metrics for Hyperspectral Image Processing using Multicore CPU and FPGA	Radiometric Correction (chai-l1r)	*Atmospheric Correction (FLAASH)	Geometric Correction (chai-l1g)	Product Data (WCPS - vis_composite)	Co-registration (ureg)
864 MHz TILEPro64 (1 core)	59.217	1298.600	185.249	44.21	33.18
864 MHz TILEPro64 (49 cores)	10.195	906.440	4.953	-	-
1.0 GHz TILE-Gx36 (1 core)	30.053	505.102	31.229	12.41	6.78
1.0GHz TILE-Gx36 (36 cores)	2.166	381.620	1.017	-	-
667MHz ARM ZC702 (1 core)	17.827	323.550	10.861	5.12	3.44
667MHz ARM ZC702 (2 cores)	10.077	283.880	5.442		-
2.2GHz Intel Core I7 (1 core)	0.723	32.161	0.643	0.514	0.386
2.2GHz Intel Core I7 (4 cores)	0.472	28.700	0.139	-	-
FPGA (Zynq 7Z020)	Implemented		Optimizing fit		

Notes: Unit is in seconds
 TILEPro64 - No floating point support
 TILEGx36 - Partial floating point support
 * Indicates time includes file I/O

Compiled with "-g -O2 -funroll-loops -fomit-frame-pointer -march=native -fopenmp"

CHAI V640
 Samples: 696
 Lines: 1800
 Bands: 283
 Data Type: 12 (UINT16)
 Data Rate: 174 Mbps



Raw Data: 1305.5184 MB
 Level 0: 1304.5248 MB
 Level 1R: 709.0848 MB

ASD Measurements at MSU PEARL

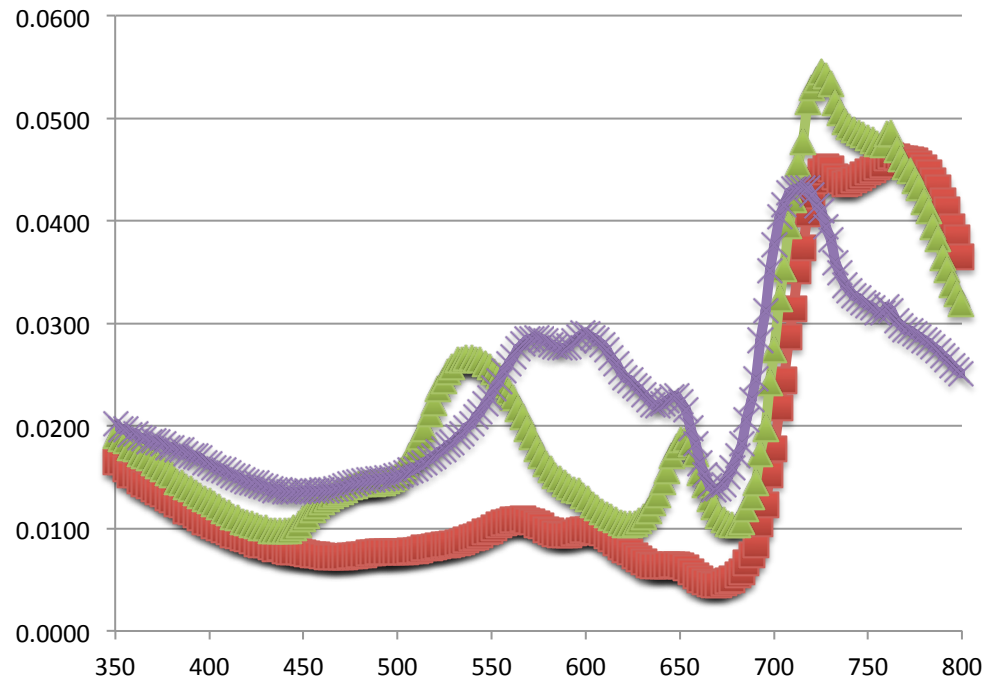
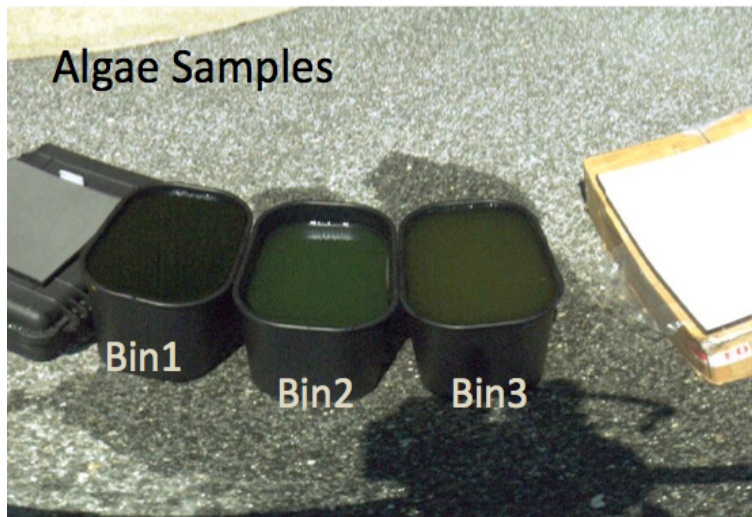

Brandywine Chai 640



- Bin 1  GoldenAlgae
- Bin 2  Blue-Green
- Bin 3  Diatom

ASD Spectra Measurements
@ CHAI 640 wavelengths
From 350 to 800 nm

Note: 800nm to 1050nm seemed too noisy

Conversion To ~Reflectance

- Calculated Average White Panel Radiance At All Wavelengths
- Divided All Bands by White Panel Radiances To Generate ~Reflectance
- Generated Composite Visible Image For Validation
- Uploaded The Three Spectra To WCPS

rgb_composite (122,86,53)



SAM golden_algae (cos Θ =.93)

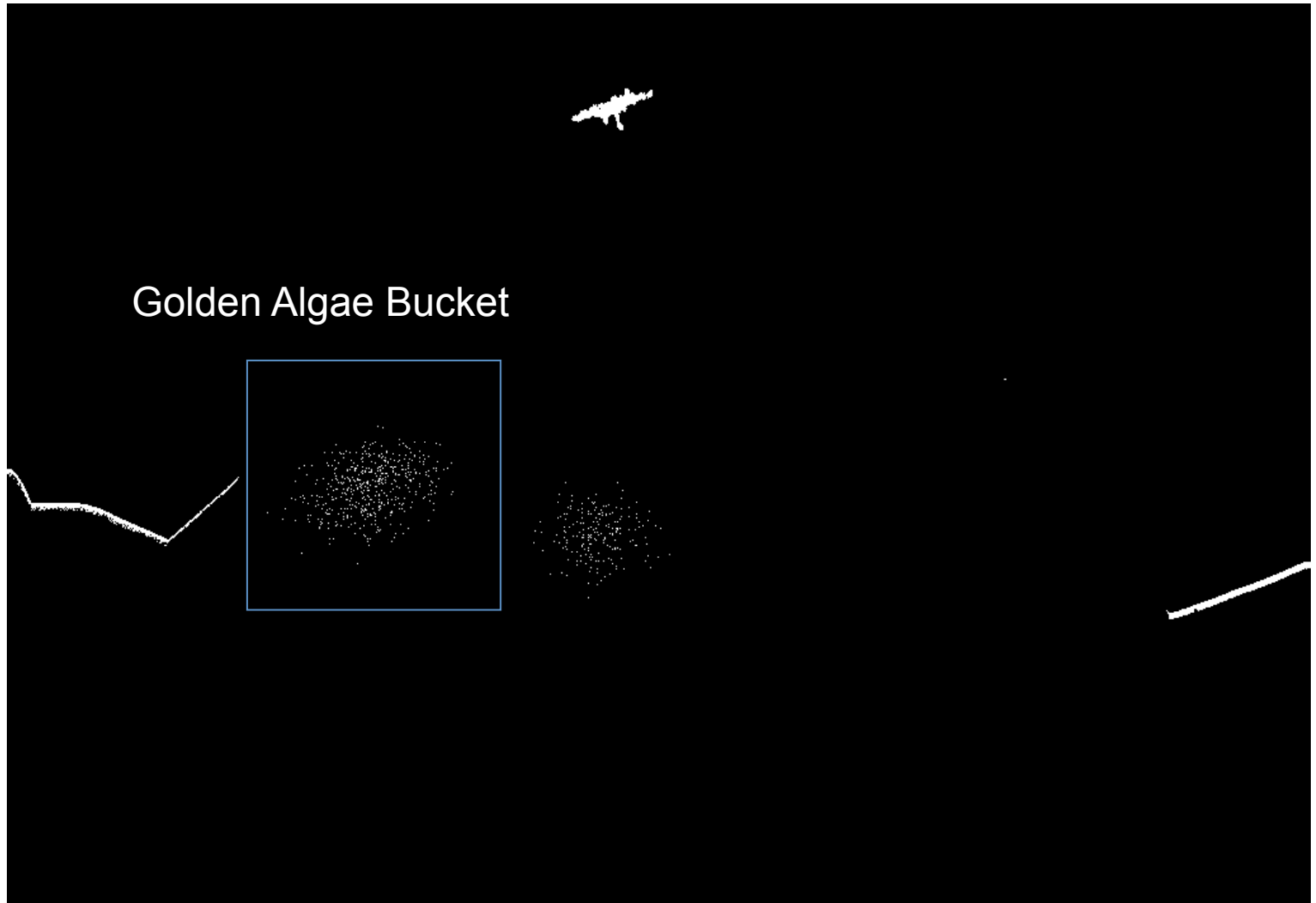

SAM blue_green_algae (cos Θ =.93)

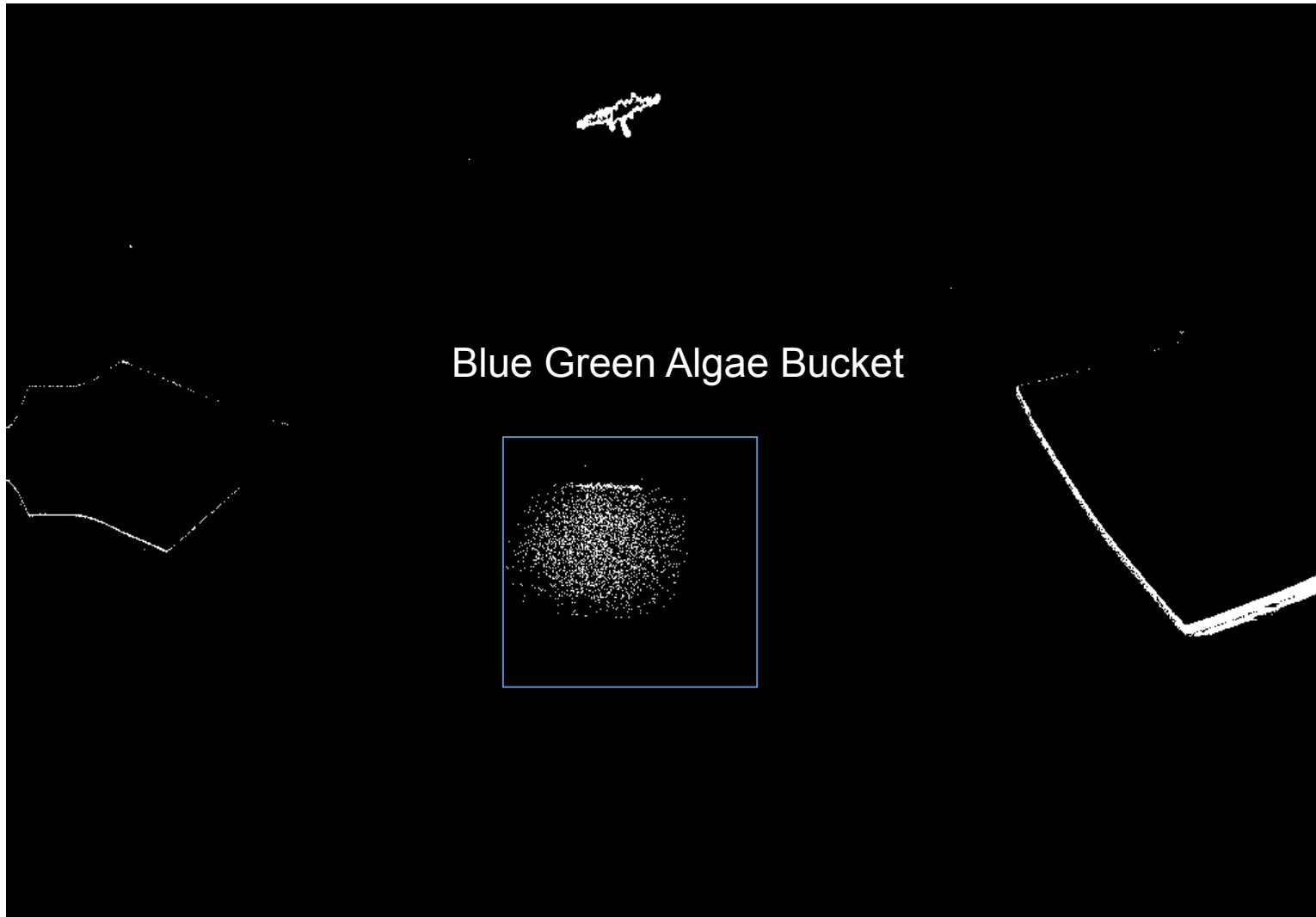

SAM Diatom

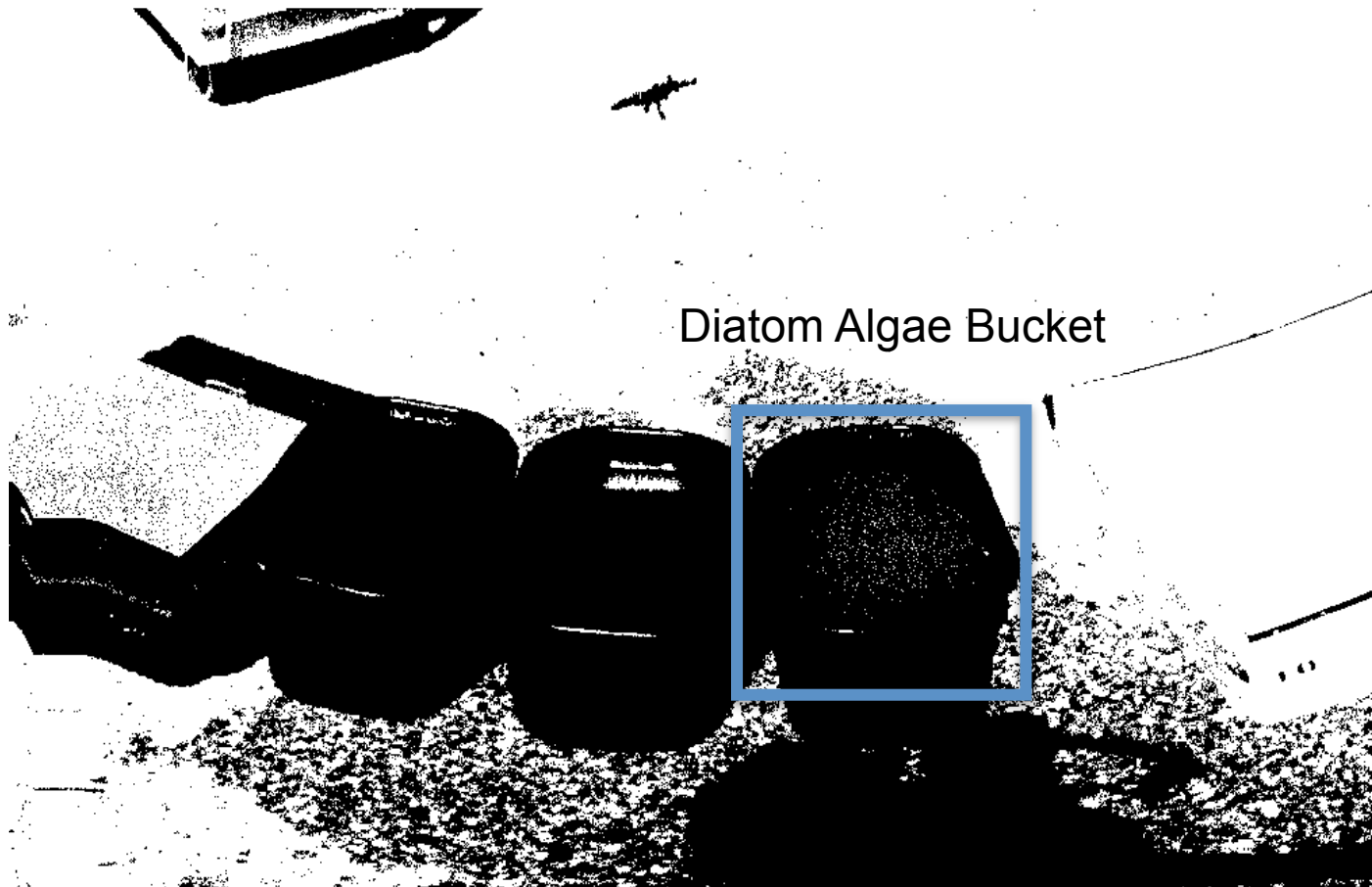

Not enough separation, angle threshold too wide open

Calibration Exercise February 27, 2014 at Pearl Center After Making ChaiV640 SW Adjustments to Get Better Instrument Response



Test setup with ChaiV640 and algae



Images of Algae with from ChaiV640



Measurements with spectrometer for calibration plates and algae

Brandywine Compact Hyperspectral Advanced Imager (CHAI v640)

SPECIFICATIONS

MECHANICALS	ESTIMATE
Size (with lens)	125 x 101 x 75 mm
Size (with telescope)	200 x 101 x 75 mm
Weight	.48 kg [.99 lbs]
Power	20 watts
Temperature Range	-20 to +50 C
<i>Size does not include NS/GPS</i>	

OPTICS	SPECIFICATION
Spectrometer Type	Dyson
Telescope	All-reflective telescope
Field of View	40 degrees
Cross Track Pixels	640
F-Number	f/2
Spectral Range	350-1080 nm (Reflective) 400-1000 nm (Refractive)
Smile Distortion	< 0.1 pixels
Keystone Distortion	< 0.1 pixels
Stray Light	< 1e-4 Point Source Transmission
Spectral Bands	256
Spectral Sampling	2.5, 5, 10 nm
Peak Grating Efficiency	88%
Slit Size	9.6 x .015 mm

IMAGE SENSOR	
Image Sensor	640 x 512, with 15 μ m pixels
Full Well Capacity	Gain 0: 500,000 Gain 1: 60,000 Gain 2: 10,000
Read Noise	Gain 0: < 63 electrons Gain 1: < 42 electrons Gain 2: < 10 electrons
Maximum Frame Rate	1000 frames/second
Quantum Efficiency	> 50% @ 380 nm 80% @ 400-900 nm > 30% @ 1000 nm
Camera Interface	USB-3
Data Acquisition	500 MB Solid State Recorder Serial Interface for GPS/INS

CHAI SOFTWARE	
Trigger Modes	Pilot, GUI, electronic, and Lat/Long triggered acquisition
Visualization	3-band RGB waterfall display of real-time and recorded data
Metadata	Temperature, pressure, and humidity
Data Format	RAW, ENVI BIL, or Processed
Processing	EXPRESSO™

