

The Sensor Management for Applied Research Technologies (SMART) Project.

Michael Goodman¹, Gary Jedlovec¹, Helen Conover², Mike Botts², Alex Robin², Richard Blakeslee¹,
Robbie Hood¹, Susan Ingenthron², Xiang Li², Manil Maskey², Karen Stephens¹

¹NASA Marshall Space Flight Center, ²University of Alabama in Huntsville

Abstract - NASA seeks on-demand data processing and analysis of Earth science observations to facilitate timely decision-making that can lead to the realization of the practical benefits of satellite instruments, airborne and surface remote sensing systems. However, a significant challenge exists in accessing and integrating data from multiple sensors or platforms to address Earth science problems because of the large data volumes, varying sensor scan characteristics, unique orbital coverage, and the steep “learning curve” associated with each sensor, data type, and associated products. The development of sensor web capabilities to autonomously process these data streams (whether real-time or archived) provides an opportunity to overcome these obstacles and facilitate the integration and synthesis of Earth science data and weather model output.

I. INTRODUCTION

The Sensor Management for Applied Research Technologies (SMART) project at the NASA Marshall Space Flight Center is developing and demonstrating the readiness of Open Geospatial Consortium (OGC) Sensor Web Enablement (SWE) capabilities that integrate both Earth observations and forecast model output into new data acquisition and assimilation strategies. The advancement of SWE-enabled systems (i.e., use of Sensor Model Language, Sensor Planning Services, Sensor Observation Services, Sensor Alert Services, and Observation and Measurement model protocols) will have practical uses in the Earth science community such as to efficiently introduce near real-time NASA satellite data into weather forecast models, generate case study data sets, improve weather forecast preparations, and autonomously task sensors in support of environmental decisions.

This paper will describe prototype sensor web capabilities applied to NASA Earth Observation System (EOS) observations. The Earth Science Office at the NASA Marshall Space Flight Center and scientists at the University of Alabama in Huntsville are implementing OGC SWE standard web services and encodings in order to explore the effectiveness of these technologies by building a

series of demonstration applications using SWE protocols and formats for all interfaces between components. We are implementing SWE protocols and services to satellite data processing systems in order to enable interoperable data ingest and plug-and-play analysis algorithms, thereby increasing access to and the development of unique scientific products in a more efficient, autonomous, and affordable way. We are demonstrating prototype capabilities by first using web-based service oriented architecture to autonomously access historical archived data for assembling case study data sets or improving weather forecasts by assimilating data into forecast model runs. Upon successful implementation using the historical data, we will implement a demonstration using real-time satellite data sets.

We are meeting the complex challenge of automating the integration of data from multiple sensors, platforms, and models by implementing a sensor web enabled environment with common protocols and formats. Within the SWE framework, there is little distinction between an instrument, model and simulation, and data processing engine. They all are termed “sensor systems” and can be described in Sensor Model Language (SensorML) as process models or chains. As sensor systems, they all produce observations that can be encoded in the Observations & Measurements (O&M) specification and be advertised and accessed through a Sensor Observation Service (SOS). Many of these sensor systems can also be tasked or configured to meet the specific needs of the user and are thus candidates for web enablement through the Sensor Planning Service (SPS). In addition, many sensor systems can produce alerts that can be advertised, published, and subscribed to through the Sensor Alert Service (SAS).

A brief OGC description of the SWE standard formats and interface definitions for describing sensors and their observations follows [1]:

- SensorML – provides a standard model and XML schema for describing sensor systems

and processes. It provides information needed for the discovery of sensors, the location (georeferencing) of their observations, and the listing of any taskable properties

- O&M – provides a standard model and XML schema for encoding the observations and measurements from a sensor, either in real time or from an archive.
- SOS – provides a standard web service interface for requesting, filtering and retrieving observations and sensor system information.
- SAS – provides a standard web service for publishing and subscribing to alerts from sensors
- SPS – provides a standard web service for requesting user-driven acquisitions and observations

II. APPLICABILITY TO EARTH SCIENCE MISSIONS

The intercomparison and validation of products derived from EOS satellites is a difficult task given the time, space, and resolution discrepancies of the satellite orbits and sensor scanning characteristics. In a validation or case study mode, this manually intensive (and, hence, time consuming) process often results in many failed attempts because of the inability to obtain any one of the many required dependent datasets. This failure necessitates the selection of a different case (i.e., the need to start the data acquisition process all over again) or the development of a new strategy for collection and intercomparison. The sensor web approach discussed in this paper addresses these limitations by implementing a SWE-based architecture to autonomously select the optimal conditions for case study selection.

A typical aspect of a research project is to determine the accuracy of a data product retrieved with a new or improved algorithm. One such example explored here is the validation of cloud-top pressure retrieved from several different sensors on various satellite platforms, such as the GOES Imager

and Sounder, MODIS on Terra and MODIS and AIRS on Aqua. An additional problem stems from the lack of adequate "ground truth" for the retrieved products. The launch of CloudSat (which contains a nadir-looking radar for accurate cloud height determination) as part of the A-train satellite system provides a unique validation source. CloudSat trails the Aqua satellite by less than a minute and provides (almost) simultaneous cloud-top pressure estimates with MODIS and AIRS along its nadir track.

The validation and case study challenge is to spatially and temporally match cloud-top pressure estimates from CloudSat with individual pixels from MODIS and AIRS (aboard Aqua), both of which have varying resolutions and scan geometries, and with the closest (in time and space) cloud-top pressure values from the GOES Imager and Sounder cloud products in geostationary orbit. An additional complication comes from the desire not to compare data where no clouds exist (erroneous comparison) and/or alternatively, to only perform the comparison or validation for a certain type (height) cloud such as cirrus. The collection of this comparison data set either from a data archive or from a real-time data stream requires the determination of the intersection between a number of varying parameters (given some window in time and space) to achieve an appropriate match. The next section will describe the implementation and use of SWE capabilities to simplify and automate this process.

III. DEMONSTRATION SCIENCE SCENARIO

The initial prototype developed for this project addresses the case study scenario described above by locating instances where the narrow CloudSat track overpasses regions of cirrus clouds as indicated by cloud top pressure values derived from GOES imagery. Note that for this prototype, the user's region of interest is assumed to be within the field of view of a GOES satellite. As shown in Figure 1, the user provides a SAS request to be notified when CloudSat data are available for an area with cloud top

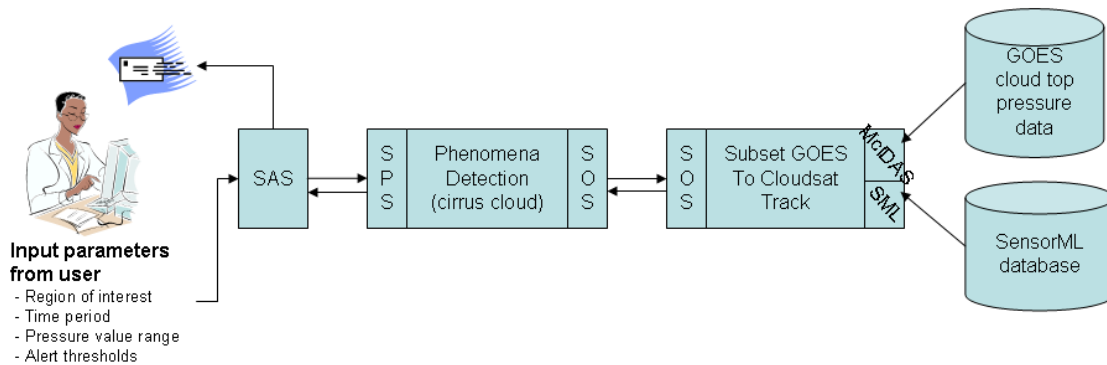

Fig. 1 Sensor web enabled processing flow for the extraction of GOES cloud top pressure data from the coincidence with in the CloudSat field-of-view.

pressure values within a given range. She specifies to the SAS the geotemporal area and range of cloud top pressure values she is interested in, along with other alert thresholds such as the number of pixels containing data values of interest.

Through a middleware agent, the SAS invokes a Sensor Planning Service (SPS) to do the required analysis. The SPS, in turn, invokes a Sensor Observation Service (SOS) to request the needed data, in this case, cloud-top pressure data derived from GOES, and a SensorML description of the CloudSat nadir track. The SOS reads each dataset in its native format, determines instances where the CloudSat intersects the user's region of interest, and subsets the GOES cloud-top pressure data to the CloudSat track. Depending on the length of time the user requests (temporal range), there may be several CloudSat overpass segments for the region of interest. Spatially coincident cloud top pressure values will be extracted from the GOES data closest in time to the CloudSat overpass. The SOS returns a set of geo-temporally located data points to the SPS, using the appropriate Observation and Measurement (O&M) schema. The data points will be structured as a series of arrays, each corresponding to a CloudSat overpass segment. The SPS examines every pixel, determining whether or not the pressure value falls within the user-specified range. For each CloudSat overpass segment, the SPS records its temporal endpoints, calculates the total number of pixels and the percentage of those pixels within the user's range, and returns these statistics to the SAS. The SAS monitors the results, and when a large enough overpass segment observing cirrus clouds is detected (as determined by user-supplied thresholds on the total number and percentage of pixels), the SAS sends an email alert to the user with the relevant statistics and temporal information. The user is then able to request CloudSat and Aqua data from that time period for a validation case study.

IV. APPLICABILITY TO EARTH SCIENCE MISSIONS - ON-DEMAND MODELING

In a real-time mode where observational data are needed to impact the decision making process at national forecast centers around the world, the requirement to quickly process and assimilate these same large data volumes from multi-sensor platforms often results in significant sub-sampling of high resolution data to accomplish the processing in a timely manner [2]. NASA's Short-term Prediction and Research Transition (SPoRT) Center [3] is demonstrating the ability to assimilate high resolution EOS data into regional forecast models to address short-term weather forecast problems. In a test-bed mode, AIRS data are being assimilated into the

Weather Research & Forecasting (WRF) model [4]; [5] to produce high resolution near real-time forecasts of sensible weather parameters (temperature, moisture, winds, and precipitation) for high impact storm systems over the Southeast U.S. While real-time AIRS data is readily available through direct broadcast downloads or internet dissemination, the decision on when to include the data and where spatially it will have the most effect for the day-to-day weather conditions over the United States is not trivial. Regular assimilation is not performed on a daily basis because of the limited availability of resources and the operational requirement of the National Weather Service for improved forecasts of high impact events [6]. Forecast improvements in low-impact weather systems may not be an effective use of resources, whereas appropriate data assimilation in evolving weather situations or with tropical systems such as hurricanes is likely a more effective use of computer time and associated manpower because of its impact - a direct affect on loss of property and lives.

The more effective inclusion of AIRS data into regional forecast models could be made possible through more autonomous processing of model data fields, Aqua satellite orbit predictions, AIRS instrument data, and required ancillary information through sensor web capabilities and services. The sensor web capabilities described for case study generation and data set validation in the previous section are being extended to provide for more autonomous operation of data collection, integration, and processing of information for data assimilation (i.e., streamlining existing manual approaches) for on-demand modeling in support of the AIRS data assimilation activities. The result will be a faster, more efficient process, and one that increases the success of data assimilation and impact on users in the decision making process. It will also provide additional data assimilation opportunities to the Earth science community.

Consider the following scenario used by SPoRT for algorithm testing of data assimilation strategies. The AIRS instrument and associated EOS science team retrieval algorithms provide vertical profiles of temperature and moisture at a 50 km horizontal spacing over a narrow swath. These data provide asynoptic observations to complement the standard weather balloon observing network. The profiles are most accurate in clear and partly cloudy regions and the quality of the AIRS retrieval is determined in real time and transmitted to the user. Chou et al. [7] demonstrated that the selective use of profiles (based on quality indicators) has had a positive impact on short term weather forecasts. AIRS data assimilation strategies used for case studies parallel the approach

to be used for real-time data assimilation. Matching AIRS data availability, quality indicators, and coverage with cloud data, model assimilation and forecast cycles, and with a particular weather feature under study maximizes impact of the data. Figure 2 shows an example of this for a typical application to the southeastern U.S. The synoptic maps for November 20 and 22, 2005 at 1200 UTC (Fig. 2a, b)

show a developing low pressure system over the Gulf of Mexico moving up the east coast and bringing heavy rains and flooding over much of the region. The inclusion of AIRS data into model forecasts of this event could provide more accurate and timely advance warning of the event. But the inclusion of the most appropriate AIRS data in the forecast model is not a trivial process.

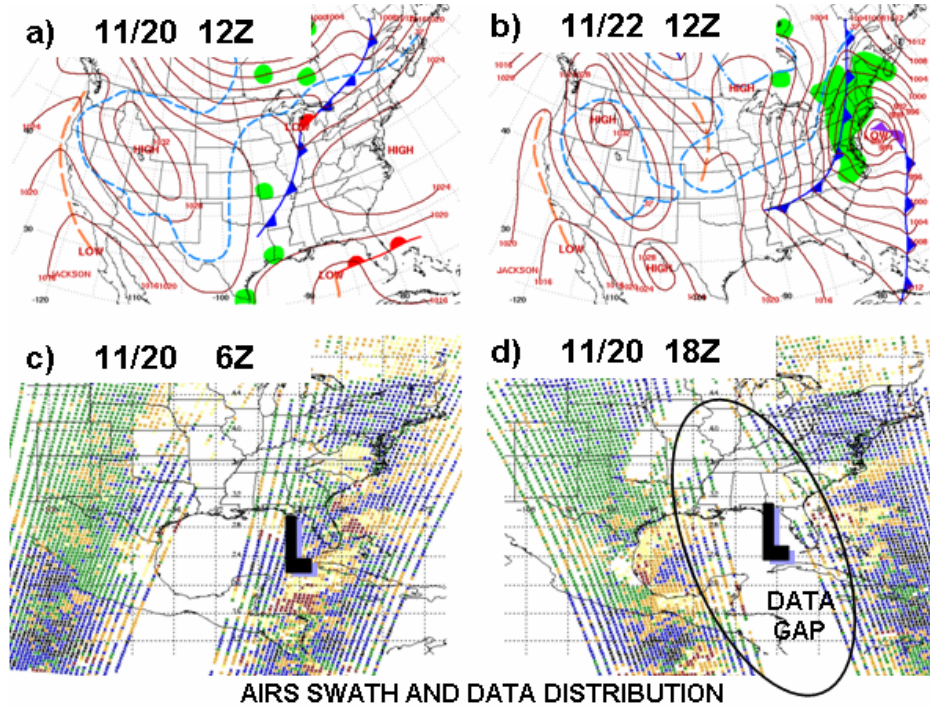

Fig. 2 Synoptic weather conditions and AIRS satellite coverage over the southeastern U.S. during the period 20-22 November 2005. Quadrant a) depicts the surface weather, b) 48-hour forecast, c) AIRS coverage at 0600 UTC on 20 November 2005 and d) AIRS cover

The process of analyzing which data sets are available and suitable for assimilation is currently a time consuming manual process. The AIRS orbital track and anticipated distribution of retrievals on the morning and afternoon of November 20 are displayed in Fig. 2c-d. Each dot in Fig. 2c-d represents a potential retrieval location and quality based on cloud cover (black and blue dots indicate highest quality retrievals and green dots the lowest quality). Typically only the highest quality retrievals are used in the assimilation process. The east coast pass of the Aqua satellite at 06Z (UTC) (Fig. 2c) provides nearly ideal coverage over the developing storm system located over the Gulf of Mexico. Note the gaps in coverage between swaths at both times, however, the gap at 18Z (UTC) is directly over the developing low pressure system. This gap could limit the impact of the AIRS data on the weather forecast if the 18Z

(UTC) data were used. The automation of this process with SWE capabilities will allow more effective assimilation of EOS data such as AIRS and lead to better weather forecasts.

IV. CONCLUSION

The SMART project's initial prototype exercises a variety of SWE components in a useful application that automates a currently manual process. The similar automation of the more complex data assimilation example will further demonstrate the applicability of SWE technologies far beyond communication with the sensors themselves. Furthermore, the use of standard SWE protocols and formats supports the interoperability of any of these components, facilitating their reuse in a variety of process chains.

REFERENCES

- [1] M. Botts, A. Robin, J. Davidson, I. Simonis, editors, 2006 *OGC 06-021, 2006*
- [2] LeMarshall, J., F. Weng, S. Lord, L-P Riishojgaard, and P. Phoebus, "The Joint Center for Satellite Data Assimilation". *Preprints 14th Conference on Satellite Meteorology and Oceanography*, Atlanta, GA, Amer. Meteor. Soc, CD-ROM, 2006
- [3] S. J. Goodman, S. J., W. M. Lapenta, G. J. Jedlovec, J. C. Dodge, and T. Bradshaw, "The NASA Short-term Prediction Research and Transition (SPoRT) Center: A collaborative model for accelerating research into operations." *Preprints, 20th Conference on Interactive Information Processing Systems (IIPS)*, Seattle, WA, Amer. Meteor. Soc., CD-ROM, P1.34. 2004
- [4] J. Michalakes, S. Chen, J. Dudhia, L. Hart, J. Klemp, J. Middlecoff, and W. Skamarock, "Development of a next-generation regional weather research and forecast model" *Developments in Teracomputing: Proceedings of the Ninth ECMWF Workshop on the Use of High Performance Computing in Meteorology*, W. Zwiefnofer and N. Kreitz, Eds., World Scientific, pp. 269–276, 2001.
- [5] W. C. Skamarock, J. B. Klemp, and J. Dudhia, "Prototypes for the WRF (Weather Research and Forecasting) model", *Preprints, Ninth Conf. on Mesoscale Processes*, Fort Lauderdale, FL, Amer. Meteor. Soc., J11–J15. 2001
- [6] C. Darden, B. Carroll, S. Goodman, G. Jedlovec, W. Lapenta, "Bridging the Gap Between Research and Operations in the National Weather Service: Collaborative Activities Among the Huntsville Meteorological Community". *NWS Technical Memorandum, NWS-SR-222*, Fort Worth, TX. 2002
- [7] S-H. Chou, B. Zavodsky, G. J. Jedlovec, and W. Lapenta. "Assimilation of Atmospheric Infrared Sounder (AIRS) data in a regional forecast model". *Preprints 14th Conference on Satellite Meteorology and Oceanography*, Atlanta, GA, Amer. Meteor. Soc, CD-ROM, P5.12. 2006