

PATHFINDER ADVANCED RADAR ICE SOUNDER: PARIS

R. Keith Raney, Carl Leuschen, and Marshall Jose*

Johns Hopkins University
Applied Physics Laboratory
Laurel, MD 20723

*University of Kansas
Center for Remote Sensing of Ice Sheets
Lawrence, KS 66045

ABSTRACT

Demonstration of ice thickness sounding from a high-altitude airborne radar was the prime objective of the PARIS NASA Instrument Incubator Project. This paper describes key features of the system, including the radar and the processing algorithm. Test flights over the ice sheets of Greenland produced good results.

1. INTRODUCTION

In July 2005, the Johns Hopkins University, Applied Physics Laboratory began "Pathfinder Airborne Radar Ice Sounder (PARIS)" funded under the NASA Instrument Incubator Program (IIP). Until PARIS was demonstrated, virtually all airborne radar sounding of ice sheets had been restricted to altitudes no higher than about 500 m above the surface, due largely to the fact that the relative level of off-nadir clutter increases with sensor altitude, leading to unacceptable results. The primary objective of this project was to demonstrate successful radar sounding of ice sheet layering and bottom topography from a high-altitude platform. This objective was met. Major contributing factors included a high-fidelity 150-MHz radar, supported by along-track partially-coherent processing. The radar was mounted on the NASA P-3, and deployed on a mission over the Greenland ice sheet in the spring of 2007. Data were recorded on board as well as displayed in flight on a quick-look processor. The data subsequently were processed in the laboratory to quantify performance characteristics, including dynamic range, sidelobe level control, and contrast improvement from the delay-Doppler algorithm.

2. RADAR DESIGN FEATURES

"High-fidelity" in this context implies very wide dynamic range, extreme linearity, and very low sidelobes generated by the transmitted pulse. The radar's architecture (Fig 1) is based on two key characteristics: signal modulation at the mean

transmitted frequency, and analog-to-digital conversion operating directly on the received signal. These techniques have proven to be essential for radar sounders [1], since they circumvent the main sources of non-linearity and harmonic generation common to all up- or down-conversion frequency schemes.

The transmit waveform is a linear frequency-modulated chirp at a 150-MHz operating frequency with a trapezoidal envelope. Such severe weighting is essential to reduce the ringing commonly associated with the initial on-off transition of weakly-weighted waveforms. The 180-W (peak) pulse has ~6 MHz bandwidth. The amplifier is class AB to help ensure the high linearity needed to suppress the internal clutter (sidelobes) generated by the chirp waveform. Laboratory measurements of the driver and power amplifier show excellent linearity with a two-tone third-order inter-modulation of at least -26 dBc at peak power. To maximize average power, the radar is operated at a PRF several times higher than the Doppler bandwidth of the received waveforms. The effective PRF can be reduced by coherent pre-summing, implemented in PARIS as a part of the subsequent data processing.

In the receiver, there is no intermediate frequency, and no analog baseband down-conversion. Instead, the signals are sampled directly following the low-noise amplifier. The sample rate is well below Nyquist, but is chosen so that the resulting spectra shift an alias of the main signal to offset baseband in a clear channel (Fig 2). The radar ice sounding application demands a dynamic range of at least 90-dB. To help support this requirement, the receiver includes variable attenuators to adjust the voltage range of the signal input to the analog-to-digital converter as well as sensitivity time control (STC) to increase the effective dynamic range of the response as a function of depth of penetration. The overall noise figure of the receiver is less than 5.5 dB with a gain of over 60 dB and a 45 dBm third-order intercept point.

The digital components in the radar consist of a field programmable gate array (FPGA) radar synchronizer, a direct digital synthesizer (DDS), and

an under-sampling analog-to-digital converter (ADC). All components of the digital subsection are clocked by a stable 66.6 MHz reference oscillator. The radar data are time-tagged by reference to GPS.

3. DATA PROCESSOR FEATURES

“Partially-coherent processing” implies the delay-Doppler technique [2], previously proven in airborne radar altimeter and low-altitude radar ice sounding embodiments [3, 4]. Figure 3 shows the logical flow of this technique as would be required for a radar altimeter. The ice sounding application requires that the range curvature correction (the “delay shift” operation) and the resolved along-track data co-registration (the “Doppler shift” operation) must account for the retarded EM propagation speed within the ice sheet. There are three major advantages (illustrated in Fig 4) that follow from this method: rejection of clutter from Doppler selectivity, finer along-track footprint resolution, and more degrees-of-freedom resulting in substantial speckle reduction. Compatible methods to reduce clutter contributions from off-nadir sources to the side of the surface track are currently under investigation.

4. RESULTS

The flights included passes over the summit ridge at an aircraft altitude of 25,000 ft, from which results (Fig 5) show internal layering, and the bottom profile at several km depth. Analysis of returns such as these verify the 90-dB dynamic range performance of the system.

5. REFERENCES

- [1] R. Croci, F. Fois, D. Calabrese, E. M. Zampolini, R. Seu, G. Picardi, and E. Flamini, "SHARAD design and operation," in *Proceedings IEEE International Geoscience and Remote Sensing Symposium*. Barcelona, Italy, 2007.
- [2] R. K. Raney, "The delay Doppler radar altimeter," *IEEE Transactions on Geoscience and Remote Sensing*, vol. 36, pp. 1578-1588, 1998.
- [3] R. K. Raney, B. L. Gotwols, and J. R. Jensen, "Optimal processing of radar ice sounding data," in *Proceedings IEEE International Geoscience and Remote Sensing Symposium*. Hamburg, Germany: IEEE, 1999.
- [4] C. Leuschen, S. Gogineni, and D. Tammana, "SAR processing of radar echo sounder data," *Proceedings, IEEE Geoscience and Remote Sensing Symposium IGARSS2000*, pp. 2570-2572, 2000.

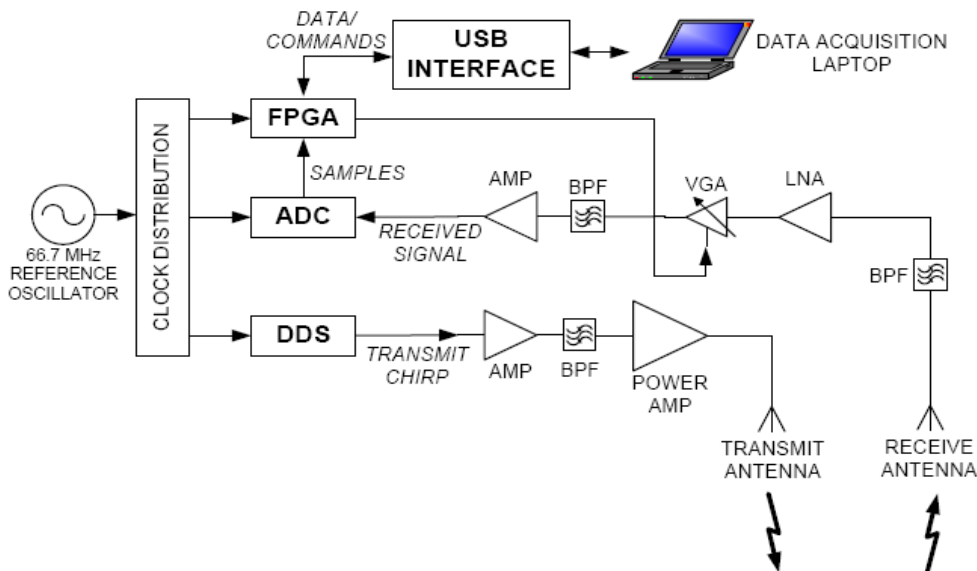

Figure 1. High-level architecture of the PARIS radar sounder.

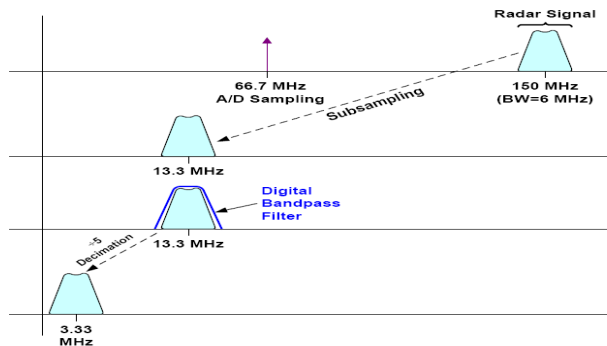

Figure 2. Sub-Nyquist alias-to-baseband A/D method

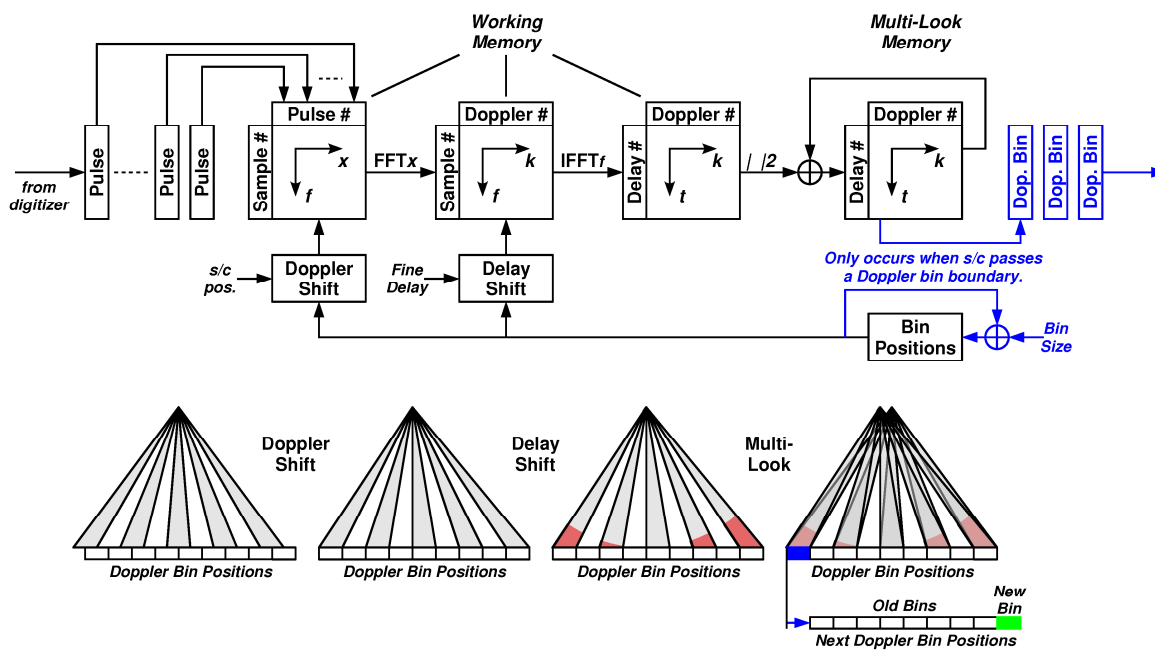

Figure 3. Logical flow of the delay-Doppler algorithm, which is the optimum processing strategy to reduce self-clutter and improve along-track spatial resolution for a nadir-viewing radar sounder.

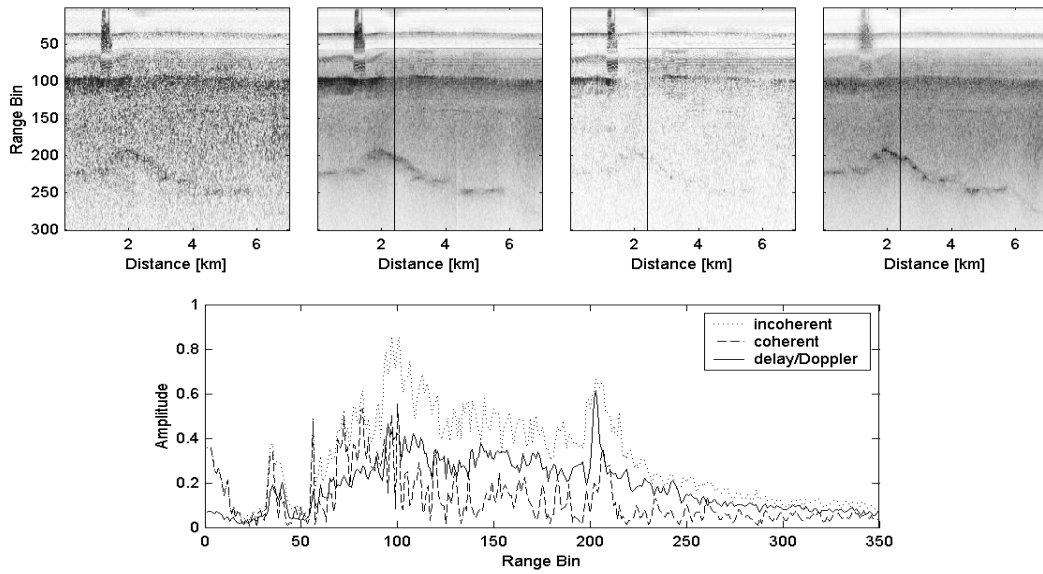

Figure 4. Processing low-altitude examples over the Greenland ice. (a) Unprocessed data. (b) Incoherent—decreased speckle with no surface clutter or resolution improvement. (c) Coherent—decreased clutter and improved resolution but no speckle reduction. (d) DD—decrease in speckle and clutter, increase in SNR, and also with improved resolution.

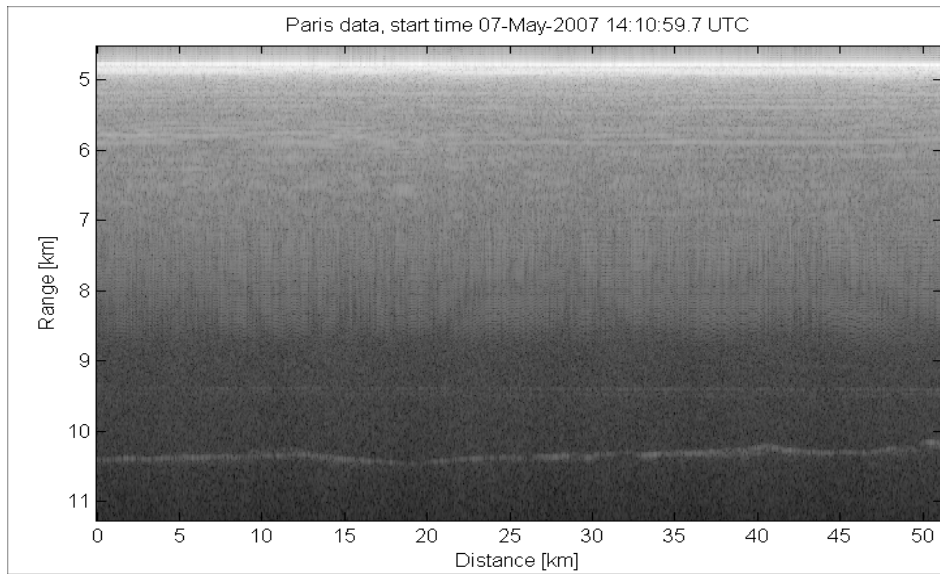

Figure 5. Example of processed data from PARIS over the crest of the Greenland ice cap. Note that the range scale must be reduced by the factor 0.6 to account for the slower EM propagation speed within the ice sheet itself. The resulting ice thickness is on the order of 3.3 km.